

WATER  
QUALITY  
MANAGEMENT AND  
AERATION IN  
SHRIMP  
FARMING



Fisheries and Allied Aquacultures Departmental Series No. 2  
Alabama Agricultural Experiment Station  
Auburn University  
Auburn University, Alabama  
Lowell T. Frobish, Director  
February 1989

Conversion Factors for English and Metric Units

| To convert column<br>1 to column 2,<br>multiply by | Column 1                       | Column 2                             | To convert column<br>2 to column 1,<br>multiply by |
|--|--------------------------------|--------------------------------------|--|
| <b>Length</b>                                      |                                |                                      |  |
| 2.540 .....  | Inches                         | Centimeters.....                     | 0.3937   |
| 0.3048 .....                                       | Feet                           | Meters.....                          | 3.281  |
| 1.609 .....  | Miles (statute)                | Kilometers.....                      | 0.6214   |
| 30.48 .....  | Feet                           | Centimeters.....                     | 0.0328   |
| 0.9144 .....                                       | Yards                          | Meters.....                          | 1.094  |
| <b>Area</b>  |                                |                                      |  |
| 0.4047 .....                                       | Acres                          | Hectares.....                        | 2.471  |
| 6.452 .....  | Square Inches                  | Square centimeters.....              | 0.1550   |
| <b>Volume</b>                                      |                                |                                      |  |
| 0.9463 .....                                       | Quart, liquid, U.S. (32 ounce) | Liter.....                           | 1.057  |
| 1.136 .....  | Quart, imperial (40 ounce)     | Liters.....                          | 0.8799   |
| 3.785 .....  | Gallon, U.S. (4 quarts)        | Liters.....                          | 0.2642   |
| 4.546 .....  | Gallon, imperial               | Liters.....                          | 0.2200   |
| 29.57 .....  | Ounce (U.S. fluid)             | Milliliters.....                     | 0.0338   |
| <b>Weight</b>                                      |                                |                                      |  |
| 28.35 .....  | Ounces (avoirdupois)           | Grams.....                           | 0.0353   |
| 0.4536 .....                                       | Pounds (avoirdupois)           | Kilograms.....                       | 2.205  |
| 1.016 .....  | Tons (gross or long)           | Metric ton.....                      | 0.9842   |
| 0.9072 .....                                       | Tons (short or net)            | Metric ton.....                      | 1.102  |
| <b>Pressure</b>                                    |                                |                                      |  |
| 70.31 .....  | Pounds per square inch         | Grams per square centimeter.....     | 0.0142   |
| 0.0703 .....                                       | Pounds per square inch         | Kilograms per square centimeter..... | 14.22  |
| <b>Other conversions</b>                           |                                |                                      |  |
| 1.12 .....   | Pounds per acre                | Kilograms per hectare.....           | 0.892  |
| 10.76 .....  | Foot candels                   | Lux.....                             | 0.0929   |

## CONTENTS

|  | Page |
|--|------|
| SALINITY.....                                  | 5    |
| Effect of Salinity on Shrimp.....              | 6    |
| Factors Influencing Salinity.....              | 7    |
| pH.....  | 8    |
| Factors Affecting pH.....                      | 9    |
| Effects on Shrimp.....                         | 10   |
| LIMING.....                                    | 10   |
| Acid-Sulfate Soils.....                        | 10   |
| SUSPENDED SOLIDS AND ORGANIC MATTER.....       | 12   |
| Decomposition.....                             | 12   |
| Control of Sediment.....                       | 15   |
| Bacterial Amendments.....                      | 15   |
| NUTRIENTS, PLANKTON, FERTILIZER, AND FEED..... | 16   |
| Plant Nutrients.....                           | 16   |
| Turbidity.....                                 | 17   |
| Fertilization.....                             | 18   |
| DISSOLVED OXYGEN.....                          | 23   |
| Solubility.....                                | 23   |
| Effects of DO on Shrimp.....                   | 25   |
| Fluctuations in DO Concentrations.....         | 26   |
| Feeding and DO.....                            | 27   |
| Oxygen Budgets.....                            | 28   |
| AERATION.....                                  | 29   |
| Aerators.....                                  | 29   |
| Paddle Wheel Aerator Design.....               | 30   |
| Aeration of Ponds.....                         | 33   |
| Aerator Placement.....                         | 35   |
| Operating Cost and Service Life.....           | 36   |
| WATER CIRCULATION.....                         | 37   |
| TOXIC METABOLITES.....                         | 38   |
| Carbon Dioxide.....                            | 39   |
| Ammonia.....                                   | 39   |
| Hydrogen Sulfide.....                          | 40   |
| WATER SUPPLY.....                              | 41   |
| WATER EXCHANGE.....                            | 43   |
| POND BOTTOMS.....                              | 45   |
| HEAVY METALS.....                              | 46   |
| PESTICIDES.....                                | 47   |
| MEASUREMENT OF WATER QUALITY.....              | 48   |
| ACKNOWLEDGMENTS.....                           | 49   |
| FIGURES.....                                   | 51   |
| BIBLIOGRAPHY.....                              | 79   |

---

FIRST PRINTING JANUARY 1989, 2M

Information contained herein is available to all without regard to race, color, sex, or national origin.



## Water Quality Management and Aeration in Shrimp Farming

Claude E. Boyd\*

Shrimp farming in brackishwater ponds is an important and rapidly growing industry in many tropical nations. Satisfactory techniques for producing shrimp larvae to stock in ponds are available, and procedures for rearing shrimp in ponds are highly developed. However, production of shrimp in ponds often is limited by water quality degradation. A large amount of information on water quality management in freshwater ponds is available (13, 59). This knowledge has not been used much in shrimp farming, but many of the methods used in freshwater aquaculture are directly applicable to brackishwater aquaculture. The purpose of this manual is to provide a simple account of water quality management for application to brackishwater shrimp ponds. The information also will be useful to those culturing other species of aquatic animals in brackishwater.

### SALINITY

Salinity is defined as the total concentration of dissolved ions in water. Salinity often is expressed in milligrams per liter (mg/l), but in aquaculture, it is more convenient to express salinity in parts per thousand (ppt or 0/00). One can divide salinity values expressed in milligrams per liter by 1,000 to get parts per thousand; e.g., 5,500 mg/l = 5.5 ppt.

Salinity of freshwater often is considered to be 0 ppt, but most inland waters contain from 0.05 to 1 ppt salinity. In arid regions, inland waters may be highly saline. Water containing more than 0.5 ppt salinity usually is not suitable for domestic purposes, and 1 ppt salinity will impart a salty taste. Seawater has a salinity of 30 to 35 ppt. Estuarine waters may range from near 0 ppt to more than 30 ppt. If sea water or estuarine water is held in a pond during dry weather, evaporation may cause salinity to increase. Fast (37) classified waters based on salinity as follows: fresh water, <0.5 ppt; oligohaline, 0.5 - 3.0 ppt; mesohaline, 3.0 - 16.5 ppt; polyhaline, 16.5 - 30.0 ppt; marine, 30.0 - 40.0 ppt; brine or hypersaline, >40.0 ppt.

Seven ions (sodium, potassium, calcium, magnesium, chloride, sulfate, and bicarbonate) contribute most of the salinity to water, table 1. The other dissolved substances in water usually contribute little to salinity or total dissolved solids, but they may be biologically important. Water usually contains only trace amounts of phosphorus, inorganic nitrogen, iron, manganese, zinc, copper, boron, and certain other elements, but small amounts of these elements are essential for phytoplankton growth.

---

\*Professor of Fisheries and Allied Aquacultures.

Table 1. Typical Concentrations of Major Ions (mg/l) in Seawater, Brackishwater, and Freshwater

| Ion         | Seawater | Brackishwater | Freshwater |
|-------------|----------|---------------|------------|
| Chloride    | 19,000   | 12,090        | 6          |
| Sodium      | 10,500   | 7,745         | 8          |
| Sulfate     | 2,700    | 995           | 16         |
| Magnesium   | 1,350    | 125           | 11         |
| Calcium     | 400      | 308           | 42         |
| Potassium   | 380      | 75            | 2          |
| Bicarbonate | 142      | 156           | 174        |
| Other       | 86       | 35            | 4          |
| Total       | 34,558   | 21,529        | 263        |

### Effect of Salinity on Shrimp

Shrimp larvae are produced or captured in waters with salinities of 28 to 35 ppt, but post larval stages often are stocked in ponds where salinity is much lower. When shrimp post larvae are stocked into ponds, they should be acclimated gradually to lower salinity to reduce stress and mortality. The acclimation rate should not exceed 1 or 2 ppt change in salinity per hour. Acclimation can be accomplished by gradually adding low salinity water to the higher salinity water in which shrimp are held. The acclimation procedure can be done at the hatchery if a source of low salinity water is available and the salinity of pond water is known. If the acclimation procedure will take more than 6 or 8 hours, post larvae should be fed. Aeration of the acclimation tank is desirable. Acclimation also may be accomplished in the pond where post larvae will be stocked. During nighttime, bags of water containing the post larvae can be floated in a pond and pond water can be poured gradually into the bags until the salinity in the bags equals the salinity of the pond water. The rate of salinity change should not exceed 1 to 2 ppt per hour.

Two species of shrimp, Penaeus merguensis (banana prawn) and P. monodon (tiger prawn), are commonly cultured in Asia. Best survival and growth of P. merguensis occur at salinities above 15 ppt, but P. monodon will survive and grow well at lower salinity (17, 47). P. monodon can tolerate freshwater for about 1 month. In South and Central America, P. vannamei is commonly cultured. This species is native to the Pacific coast. Salinities of 15 to 25 ppt are considered ideal, but P. vannamei can be cultured successfully at lower and higher salinities. In Ecuador, many farmers claim that this species can be grown in freshwater. Although P. vannamei can tolerate freshwater for several weeks, practical experience indicates that a salinity of at least 0.5 to 1.0 ppt is necessary for survival and growth. Hand-held refractometers (salinometers) used by shrimp farmers do not measure salinity accurately when salinity is low. Therefore, the salinity is not necessarily 0 ppt when a salinometer indicates 0 ppt. Low salinities can be estimated

from chloride concentrations; chloride analysis is not difficult and may be made with water analysis kits.

### Factors Influencing Salinity

Shrimp farming is done in low-lying coastal areas where seawater and freshwater mix. Salinity concentrations in rivers and canals that supply water for shrimp ponds are regulated by the proportions in which seawater and freshwater mix. Where a small river runs into the sea, estuarine water has high salinity. Salinity is lower where a large river flows into the sea. Most shrimp farming is conducted in the tropics where wet and dry seasons are well defined. During the wet season, river discharge increases and salinity declines in estuaries. Conversely, river discharge decreases during the dry season and salinity increases in estuaries. Data from Thailand (17) will be used to illustrate this concept. Monthly rainfall at Bangkok, Thailand, and salinity of water at mouths of four major rivers which discharge into the Gulf of Thailand in the vicinity of Bangkok are presented in table 2. A short distance upstream from the river mouths, salinity may be extremely low during the wet season. Shrimp ponds are filled with water from canals which receive their flow from the rivers. Hence, during the wet season, water for shrimp ponds in some areas of Thailand will have low salinity.

Table 2. Normal Monthly Rainfall at Bangkok, Thailand, and Salinity of Water at Mouths of Four Major Rivers

| Month     | Rainfall,<br>mm | Salinity (ppt) |             |              |                |
|-----------|-----------------|----------------|-------------|--------------|----------------|
|           |                 | Bang<br>Pakong | Tha<br>Chin | Mae<br>Klong | Chao<br>Phraya |
| January   | 10.3            | 31.2           | 24.5        | 27.6         | 24.0           |
| February  | 30.7            | 31.2           | 28.8        | 26.9         | -              |
| March     | 23.7            | 32.1           | 32.8        | 28.7         | -              |
| April     | 63.5            | 32.0           | 23.8        | 23.1         | 23.2           |
| May       | 185.3           | 29.3           | 19.5        | 24.2         | 15.9           |
| June      | 159.8           | 10.3           | 18.6        | 23.7         | 22.2           |
| July      | 170.8           | 7.3            | 8.0         | 6.5          | 23.1           |
| August    | 198.2           | 5.6            | 13.5        | 3.3          | 15.4           |
| September | 341.8           | 7.2            | 8.6         | 16.1         | 14.3           |
| October   | 221.3           | 18.5           | 22.2        | 13.5         | 18.3           |
| November  | 44.0            | 28.2           | 30.2        | 26.6         | 19.3           |
| December  | 8.0             | 27.9           | 22.6        | 28.8         | 31.4           |

The situation described for Thailand is common to low-lying coastal areas of other nations. Rainfall and salinity of pond water on a shrimp farm near Guayaquil, Ecuador, are provided in table 3. Ponds were filled with water from the Guayas River, and 10% water exchange was made daily. The salinity of the river dropped drastically during the wet

season and pond water contained less than 5 ppt salinity for 3 months. Further upstream, river water may become fresh during the wet season and the water for shrimp ponds may be between 0 and 0.5 ppt for 3 or 4 months. In some areas where ponds have low salinity for long periods, it may be possible to develop salt-water wells for discharging saline ground water into ponds to increase salinity.

Evaporation rates are high in the tropics and this concentrates dissolved ions in pond water. Salinities above 35 ppt are common in some areas during the dry season. Continual flushing of water through ponds is the only procedure for reducing salinity.

Table 3. Monthly Rainfall Totals and Average Salinity of Pond Water at a Shrimp Farm Near Guayaquil, Ecuador

| Month     | Rainfall,<br>mm | Salinity in shrimp ponds,<br>ppt |
|-----------|-----------------|----------------------------------|
| January   | 521             | 23.8                             |
| February  | 206             | 8.4                              |
| March     | 51              | 4.2                              |
| April     | 203             | 4.1                              |
| May       | 10              | 3.8                              |
| June      | 0               | 5.0                              |
| July      | 0               | 9.2                              |
| August    | 0               | 10.2                             |
| September | 0               | 14.6                             |
| October   | 0               | 20.7                             |
| November  | 0               | 22.3                             |
| December  | 76              | 23.1                             |

### pH

The term "pH" refers to the hydrogen ion concentration in water; more generally, pH refers to how acidic or basic a water is. For practical purposes, water with a pH of 7 is considered neither acidic nor basic; it is said to be neutral. When the pH is below 7, a water is said to be acidic. Water with a pH above 7 is considered basic. The pH scale extends from 0 to 14; the greater the departure of the pH from 7, the more acidic or basic a water. The above explanation of pH will suffice for some, but more details are provided below:

The pH concept is based on the ionization of water. A fixed number of water molecules dissociate to give hydrogen ion ( $H^+$ ) and hydroxyl ion ( $OH^-$ ). The product of the molar concentrations of  $H^+$  and  $OH^-$  will always equal  $10^{-14}$ . We may write:

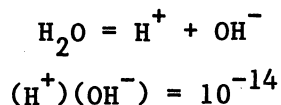



Concentrations of  $H^+$  and  $OH^-$  are equal in pure water, so we may substitute  $H^+$  for  $OH^-$  and get:

$$(H^+)(H^+) = 10^{-14}$$

$$(H^+) = 10^{-7}.$$

By definition, pH is the negative logarithm of the hydrogen ion concentration:

$$pH = -\log(H^+).$$

For pure water,  $(H^+) = 10^{-7}$  molar, and it follows that pH is 7:

$$pH = -\log(10^{-7}) = -(-7) = 7$$

Pure water is neither acidic nor basic, because  $H^+$  (acidity) and  $OH^-$  (basicity) are equal in concentration.

#### Factors Affecting pH

The pH of normal brackishwater usually is between 7 and 9. Phytoplankton blooms often develop in shrimp ponds. Phytoplankton obtain  $CO_2$  (carbon dioxide) for use in photosynthesis from the  $HCO_3^-$  (bicarbonate)- $CO_2$  equilibrium system as follows:

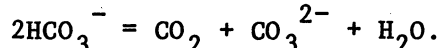

As  $CO_2$  is removed, the reaction progresses to the right of the equation and  $CO_3^{2-}$  (carbonate) accumulates. Hydrolysis of  $CO_3^{2-}$  occurs according to the following reaction:

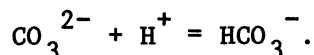

Notice that two  $HCO_3^-$  ions give one  $CO_2$  molecule and one  $CO_3^{2-}$  ion, but hydrolysis of one  $CO_3^{2-}$  ion only replaces one  $HCO_3^-$  ion. Furthermore, only a portion of the  $CO_3^{2-}$  hydrolyzes. Hydrogen ion is derived from the dissociation of water:

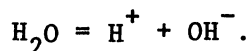

The equilibrium constant for the ionization of water must be maintained, that is:

$$(H^+)(OH^-) = 10^{-14}.$$

Hence, when  $H^+$  is used in the hydrolysis of  $CO_3^{2-}$ , more water must dissociate to maintain the equilibrium constant of water. As a result, there is more  $OH^-$  and less  $H^+$  than when photosynthesis started. Thus, pH rises as phytoplankton removes  $CO_2$  from water.

Because phytoplankton uses  $CO_2$  during daylight, the pH of water increases during the day. At night, no  $CO_2$  is removed by phytoplankton, but all pond organisms release  $CO_2$  from respiration. This  $CO_2$  reacts

with  $\text{CO}_3^{2-}$  and  $\text{H}_2\text{O}$  to form  $\text{HCO}_3^-$ ; the  $\text{HCO}_3^-$  dissociates to release  $\text{H}^+$  and the pH declines. The daily cycle in pH is illustrated in figure 1. However, the daily fluctuation in pH is not always as great as shown in this figure.

For those not adept in chemistry, it is sufficient to remember that  $\text{CO}_2$  is an acid. Removal of  $\text{CO}_2$  will make the water less acidic (pH will rise), while addition of  $\text{CO}_2$  will make the water more acidic (pH will fall).

### Effects on Shrimp

There are few data on the effect of pH on shrimp, but it is safe to assume that shrimp respond to pH in much the same way as fish. The effect of pH on aquaculture species is generalized below (13):

| <u>pH</u> | <u>Effect</u>        |
|-----------|----------------------|
| 4         | Acid death point     |
| 4-6       | Slow growth          |
| 6-9       | Best for growth      |
| 9-11      | Slow growth          |
| 11        | Alkaline death point |

Brackishwaters are well buffered against pH change, and pH will seldom fall below 6.5 or rise above 9. Therefore, adverse effects of pH on shrimp are uncommon. There are instances where acidic soils are a problem in shrimp farming; this will be discussed later.

### LIMING

Total alkalinity is defined as the total concentration of titratable bases in water. Primary bases in water are  $\text{HCO}_3^-$  and  $\text{CO}_3^{2-}$  ions. Total alkalinity traditionally has been expressed as milligrams per liter of equivalent calcium carbonate ( $\text{CaCO}_3$ ). Total hardness is defined as the total concentration of divalent cations in water, also expressed as milligrams per liter of  $\text{CaCO}_3$ . Calcium and magnesium ions are the major divalent cations in water.

In freshwater aquaculture, alkalinity and hardness often are important considerations. The concentration of each variable should exceed 20 mg/l as  $\text{CaCO}_3$ . When alkalinity and hardness are too low, lime is applied to increase their concentrations. In brackishwater, alkalinity and hardness are usually high, so these variables are seldom important in management of shrimp ponds. However, there are areas where soils are acidic and lime may be required.

### Acid-Sulfate Soils

Shrimp farms sometimes are constructed in areas once covered by saline and brackishwater tidal swamps and marshes (34, 53). When rivers with a heavy sediment load emptied into the sea, sediment was deposited near the shore. After the deposits rose above mean low water level, vegetation became established. As deposition continued, the coast slowly accreted, and a swamp forest developed. In the swamp forest,

tree roots trapped organic and inorganic debris, and decomposition of dense masses of organic debris resulted in anaerobic conditions. As a result, sulfur reducing bacteria became abundant, and sulfide produced by the bacteria accumulated in pore spaces in sediment as hydrogen sulfide (H<sub>2</sub>S) or combined with iron to form precipitates of iron sulfides. Iron sulfides underwent further chemical reaction to form iron disulfide that crystallized to form iron pyrite.

As long as sediments containing pyrites are submerged and anaerobic, they remain reduced and change little. However, if they are drained and exposed to the air, oxidation results, and sulfuric acid is formed. The summary reaction for sulfuric acid formation from iron pyrite (34) is:

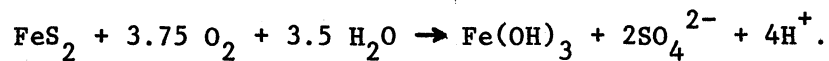

The Fe(OH)<sub>3</sub> crystallizes as a reddish brown material in the sediment. After draining, a sediment containing pyrite is called an acid-sulfate soil or a "cat's clay."

When aerobic, acid-sulfate soils will have a pH below 4.0. The pH of acid-sulfate soils often will decrease as much as 3 units upon drying (39). Field identification of acid-sulfate soils can sometimes be made by the smell of hydrogen sulfide from disturbed soil, but the positive test is to measure pH before and after drying.

In ponds, the problem with acid-sulfate soils usually originates on the levees. Pond bottoms are usually flooded and anaerobic, so sulfuric acid does not form. However, levees dry and sulfuric acid formed during dry periods enters ponds in runoff after rains. Acidity on levees can be controlled by liming and establishing good cover with an acid-resistant species of grass. A method for determining the lime requirement of acid-sulfate soils is provided by Boyd (13).

Brinkman and Singh (27) developed a method for rapid reclamation of ponds with acid-sulfate soils. The procedure is as follows:

1. In the early part of the dry season, dry the pond and harrow thoroughly.

2. Fill with brackishwater. Measure the pH of the water frequently. The pH will drop from that of sea water (7 to 9) to below 4. Once the pH has stabilized, drain the pond. Repeat this procedure until the pH stabilizes at a pH above 5. Often, three or more drying and filling cycles may be required.

3. At the same time the pond is being reclaimed, acid must be removed from the surrounding levees. To achieve this, level the levee tops and build small bunds along each side of the levee tops to produce shallow basins. Fill basins with brackishwater. When the pond is drained for drying, also drain the small basins on the levee tops for drying. Repeat if necessary. Finally, remove the bunds and broadcast agricultural limestone over the tops and sides of levees at 0.5 to 1.0 kilograms per square meter (kg/m<sup>2</sup>).

4. Once the last drying and refilling cycle is complete, broadcast agricultural limestone over the pond bottom at 500 kilograms per hectare

(kg/ha). Fertilize the pond with manures or chemical fertilizers as necessary to promote phytoplankton blooms.

5. To prevent fish kills by seepage of acid from levees, check pH frequently, and apply agricultural limestone if necessary.

Soils which do not contain iron pyrite may be acidic because of exchange acidity (13). However, brackishwater has a high alkalinity, and lime applications would probably be of little value to shrimp ponds without highly acid-sulfate soils on levees. A method for determining the lime requirement of pond soils with only exchange acidity is provided by Pillai and Boyd (50). It should be noted that acid-sulfate soils also contain exchange acidity.

### **SUSPENDED SOLIDS AND ORGANIC MATTER**

Where shrimp are produced in brackishwater ponds, the estuarine water used to fill the ponds often has a heavy load of suspended solids. These solids consist of soil particles and particles of organic matter held in suspension by turbulence. The origin of suspended soil particles is erosion in the drainage basins of rivers. Deforestation and poor soil management practices in agriculture are major causes of erosion. After waters from canals or rivers are pumped into ponds, turbulence decreases and suspended solids settle. Over time, this process will cause a pond to fill with sediment and become more shallow. Sediment often has a large organic matter content, and degradation of this organic matter by bacteria may be a major demand for oxygen.

Water also contains dissolved and particulate matter which will not settle out. This material often is primarily organic, and it is derived from contact of runoff with vegetative remains, from phytoplankton production within the water, and from pollution. Dissolved and particulate matter also exert an oxygen demand.

### **Decomposition**

As mentioned above, settleable solids are deposited on the pond bottom, and organic matter has an oxygen demand. Although sediment accumulation may be troublesome, the oxygen demand of sediment and of particulate and dissolved organic matter has more serious consequences. Degradation of organic matter is accomplished by microorganisms that use it for food. Factors affecting the rate of organic matter decomposition are temperature, pH, and the nature of the organic matter. Decomposition increases with increasing temperatures between 0°C and 35°C and with increasing pH up to about pH 8.5. Simple organic molecules (sugars, proteins, and fats) tend to degrade faster than more complex ones (cellulose, lignin, and tannins). Microorganisms capable of degrading organic matter are present in all ponds, and their abundance will increase when organic matter is increased. Temperature and pH in shrimp ponds usually are ideal for growth of microorganisms. Organic matter that has a high concentration of nitrogen relative to its concentration of carbon (low C/N ratio) will decompose faster than a material with a high C/N ratio. Additionally, more nitrogen will be released to the environment as ammonia when a substance with a low C/N ratio decomposes (2, 4).

Bacteria contain about 10% N and 50% C on a dry weight basis. They have a carbon assimilation efficiency of about 5%. This means that for every 100 grams (g) of substrate carbon, bacteria will convert 5 g to bacterial tissue. Bacteria are roughly 50% carbon, so 100 g of substrate carbon would yield 10 g of bacteria. A 10-g mass of bacteria would contain 1 g of nitrogen.

Suppose that 100 kg of dry organic matter, containing 2% N and 40% C (C/N ratio =  $40/2 = 20$ ), is decomposed by bacteria in a pond. The organic material contains 40% C, or 40 kg C ( $100 \times 0.4 = 40$  kg). Bacteria will convert about 5%, or 2 kg ( $40 \times 0.05 = 2$  kg) of the carbon in the organic matter to bacterial carbon. This amounts to 4 kg ( $2 \div 0.5 = 4$  kg) of bacteria. The bacteria are 10% N, and 4 kg of bacteria will contain  $4 \times 0.1 = 0.4$  kg of nitrogen. The organic matter contained 2 kg of nitrogen ( $100 \times 0.02 = 2$  kg). Hence, 1.6 kg of nitrogen would be released (or mineralized) to the environment as ammonia.

If the 100 kg of dry organic matter contained 40% C but only 0.3% N (C/N ratio =  $40/0.3 = 133$ ), decomposition would be slow and no nitrogen would be released to the environment:

- (i) 100 kg organic matter  $\times$  40% C = 40 kg C in the organic matter.
- (ii) 100 kg organic matter  $\times$  0.3% N = 0.3 kg N in organic matter.
- (iii) 40 kg C in organic matter  $\times$  5% carbon assimilation efficiency = 2 kg C in bacteria.
- (iv) 2 kg C in bacteria  $\div$  50% carbon in bacteria = 4 kg bacteria.
- (v) 4 kg bacteria  $\times$  0.1 kg N/kg bacteria = 0.4 kg N in bacteria.
- (vi) 0.4 kg N needed by bacteria - 0.3 kg N in organic matter = 0.1 kg N shortage.

If an organic material is very low in nitrogen, there will not be enough nitrogen in it to effect complete decomposition. In this event, bacteria will remove nitrate and ammonia from pond water (immobilization of nitrogen) for use in decomposition of matter. Also, bacteria may die and the nitrogen in dead bacterial cells may be recycled. Nevertheless, the rate of decomposition generally increases as the proportion of nitrogen to carbon in an organic residue increases (C/N ratio becomes smaller). This principle is illustrated below by the rates of oxygen consumption by bacteria decomposing aquatic plant residues of different nitrogen concentrations (4):

| <u>% N in residue</u> | <u>Oxygen consumption (mg/liter per day)</u> |
|-----------------------|--|
| 1.48                  | 0.22   |
| 3.29                  | 0.64   |
| 3.83                  | 0.93   |
| 5.92                  | 1.86   |

The amount of oxygen needed to completely decompose organic matter to CO<sub>2</sub> and water can be calculated approximately. Suppose that 100 kg of dry organic matter containing 40% C is decomposed. There is 40 kg of C in the organic matter. The approximate equation for decomposition is:

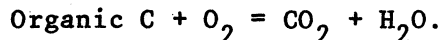

We may treat the equation stoichiometrically as follows:

(i) 40 kg organic C produces 40 kg C in CO<sub>2</sub>

(ii) 40 kg C in CO<sub>2</sub> multiplied by the ratio of CO<sub>2</sub> to C (44/12) will give the weight of CO<sub>2</sub> produced, that is:

$$40 \text{ kg C} \times (44/12) = 146.7 \text{ kg CO}_2$$

(iii) Amount of oxygen used may be obtained by the following proportionality because, in final analysis, each molecule of carbon will react with one molecule of oxygen to produce one molecule of carbon dioxide:

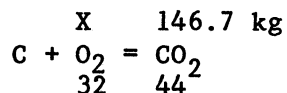

$$X = 106.7 \text{ kg oxygen}$$

Thus, 106.7 kg oxygen would be consumed by bacteria while completely degrading 100 kg of organic matter containing 40% C. Expressed in more general terms, each kg of organic carbon would require 2.67 kg of oxygen for conversion to carbon dioxide.

In reality, organic matter usually does not decompose completely. The actual oxygen demand of organic matter in shrimp ponds over a 1-year period likely would probably be about 70% of the demand calculated by the procedure illustrated above.

Suppose that the sedimentation rate in a shrimp pond is 100,000 kg/ha per crop [a layer of sediment of approximately 1.5 centimeters (cm) in depth over the entire pond bottom] and the sediment contains 4% organic matter. Organic matter is usually about 40% C. The organic matter input rate in sediment would be 4,000 kg/ha (100,000 x 0.04). This amount of carbon would be 1,600 kg/ha (4,000 x 0.4). The oxygen demand of the sediment would be:

$$1,600 \text{ kg organic C/ha} \times 2.67 \text{ kg O}_2/\text{kg organic C} \times 0.70 = 2,990 \text{ kg O}_2/\text{ha}.$$

Over a 135-day production cycle, this oxygen demand is equal to 22.1 kg O<sub>2</sub>/ha per day. For a pond 1 m deep, the oxygen demand calculated above would equal the loss of 2.2 mg/l of dissolved oxygen from the water each

day. Such a decomposition is not unreasonable; rates similar to this have been reported for ponds (9, 24).

Organic matter suspended or dissolved in water also exerts an oxygen demand. This subject will be considered in the section on plankton.

### **Control of Sediment**

The present methods of sediment control involve removing sediment from ponds periodically at the end of each growing season when ponds are drained, dredging sediment from undrained ponds, and using sediment ponds or canals to remove the bulk of sediment before water is discharged into production ponds. The use of sediment ponds is the best approach to sediment control.

Sediment ponds should be as deep as possible to maximize storage. If water levels in sediment ponds are 40 to 50 cm higher than those in production ponds, this will facilitate transfer of water to production ponds. Sediment ponds should be subdivided so that sedimentation will occur in stages. A sediment pond is illustrated in figure 2. In extensive culture of shrimp, sediment ponds could be constructed inside existing production ponds. Separate sediment ponds would be needed on intensive farms. It also is possible to construct a large water supply canal and use the canal as a settling basin, figure 3. This design is particularly suitable for new construction.

In Ecuador, sedimentation is especially heavy, for water from the Guayas River contains a tremendous sediment load. Many shrimp farms use the water supply canal for sedimentation and employ a floating dredge for removing sediment. On some farms, the initial part of the water supply canal is dual. In this way, the dredging operation can be alternated between canals.

The size of sediment ponds must be determined on a farm to farm basis. The size will depend upon sediment pond depth, size of production ponds, rate that solids settle from the water, and desired water exchange rate. Sedimentation of some soils is accelerated by dissolved salts in brackishwater, figure 4. However, for other soils, sedimentation is not rapid even at high salinity.

Aluminum sulfate (alum) often is used to flocculate suspended solids so that they will settle quickly (10). Alum is too expensive to be used in shrimp farming.

### **Bacterial Amendments**

Several companies are selling suspensions of bacteria which they claim will destroy organic matter in ponds and improve conditions for growth of fish and shrimp. These suspensions contain ordinary bacteria which are already in ponds. Research has demonstrated that treatment of aquaculture ponds with bacterial amendments is not worthwhile (26).

## NUTRIENTS, PLANKTON, FERTILIZER, AND FEED

Phytoplankton is the base of the food web in shrimp ponds. In semi-intensive and intensive culture, shrimp are provided commercial feeds. Phytoplankton use inorganic nutrients and sunlight to produce organic matter by photosynthesis. The photosynthetic process may be illustrated by the following equation:

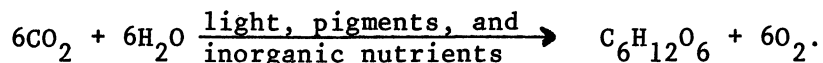

Photosynthesis is a phototropic reaction in which plant pigments such as chlorophyll utilize light energy to reduce inorganic carbon ( $\text{CO}_2$ ) to carbohydrate. Oxygen is released in the process; photosynthesis is the primary source of dissolved oxygen (DO) in aquaculture ponds.

### Plant Nutrients

A large number of inorganic elements are required for phytoplankton growth. Most species require at least the following: carbon, hydrogen, oxygen, nitrogen, sulfur, phosphorus, chloride, boron, molybdenum, calcium, magnesium, sodium, potassium, zinc, copper, iron, and manganese. Diatoms also require silicon. Phytoplankton make oxygen by photosynthesis, and they obtain hydrogen from water. Carbon dioxide enters water from the atmosphere, so it usually is present at sufficient concentration.

Nitrogen and phosphorus are most likely to limit phytoplankton growth. Typical concentrations of plant nutrients in pond water and in phytoplankton are shown in table 4. Concentration factors indicate how much of each element is accumulated by phytoplankton above concentration of the element in water. There is less nitrogen and phosphorus in pond water relative to phytoplankton needs than for other elements.

In brackishwater ponds with moderate or high salinity, diatoms are the dominant phytoplankton. Diatoms require fairly large amounts of nitrogen, and nitrogen often is as important or even more important than phosphorus as a limiting factor. When salinity is low, blue-green algae may become abundant in shrimp ponds. Many species of blue-green algae can fix elemental nitrogen ( $\text{N}_2$ ), so they can grow well without a combined source of nitrogen (nitrate or ammonia) provided phosphorus is plentiful.

In many nations, shrimp ponds are supplied waters that are polluted with domestic sewage. This water contains moderate to high concentrations of nitrate, ammonia, and phosphate. When held in ponds, this water usually will produce phytoplankton blooms. In ponds where feeds are applied, excretory products from shrimp add ammonia and phosphate to water. If ponds are constructed in areas where waters are not polluted with sewage, it will be necessary to apply inorganic fertilizers or manures to foster phytoplankton growth.



Table 4. Concentrations of Elements in Seawater and Phytoplankton

| Element    | Seawater, ppm | Phytoplankton, ppm <sup>1</sup> | Concentration factor |
|------------|---------------|---------------------------------|----------------------|
| Phosphorus | 0.02          | 187                             | 9,350                |
| Nitrogen   | .25           | 2,000                           | 8,000                |
| Iron       | .01           | 10                              | 1,000                |
| Manganese  | .002          | 2                               | 1,000                |
| Copper     | .003          | 1                               | 333                  |
| Silicon    | 3.0           | 500                             | 167                  |
| Zinc       | .01           | 1                               | 100                  |
| Carbon     | 28            | 12,000                          | 43                   |
| Potassium  | 380           | 250                             | .7                   |
| Calcium    | 400           | 250                             | .6                   |
| Sulfur     | 900           | 175                             | .2                   |
| Boron      | .8            | .1                              | .1                   |
| Magnesium  | 1,340         | 125                             | .1                   |
| Sodium     | 10,500        | 25                              | .002                 |

<sup>1</sup>Wet weight basis; assumed 2.5% dry weight.

### Turbidity

There are two basic types of turbidity in shrimp ponds: (1) that resulting from phytoplankton blooms, and (2) that caused by suspended soil particles. Both kinds of turbidity restrict light penetration into pond waters, and less light at pond bottoms discourages the growth of troublesome filamentous algae and aquatic weeds. However, turbidity from phytoplankton is much more desirable than turbidity from suspended soil particles. Phytoplankton represents the base of the food web that culminates in shrimp. Clear ponds have little phytoplankton, and there may be little natural food for shrimp. In some clear ponds, algae grow on the bottom (benthic algae) and provide natural food for shrimp, but most pond managers prefer a pond with a phytoplankton bloom. Clear ponds usually have low concentrations of plant nutrients, so chemical fertilizers or manures should be applied to promote phytoplankton blooms and provide more natural food for shrimp and greater turbidity. Excessive phytoplankton blooms in shrimp ponds can cause oxygen depletion (see section on Dissolved Oxygen).

Turbidity in pond waters can be measured most easily with a Secchi disk, figure 5. The Secchi disk is a 20-cm-diameter disk which is weighted on the underside. Its upper surface usually is painted with alternate black and white quadrants. The disk is attached to a graduated rope. To use a Secchi disk, lower it into the water until it just disappears and record the depth. Raise the disk until it just reappears and again record the depth. The average of depth readings is the Secchi disk visibility. Optimum Secchi disk visibility for shrimp ponds is 40 to 60 cm. It must be noted that the Secchi disk visibility is affected by both types of turbidity. The individual taking Secchi

disk readings must decide if the turbidity is from phytoplankton, suspended soil particles, or both.

### **Fertilization**

Shrimp production can be greatly increased by applications of fertilizer, but much greater production can be achieved through the combination of fertilization and feeding. In ponds, shrimp use a lot of natural food, so it is not clear how much of the increased production realized from feeding occurs from the shrimp eating the feed directly and how much occurs from the degradation products of the feed stimulating the production of natural food organisms for shrimp. Production can be increased more by feeding than by fertilization, so shrimp apparently derive considerable nutriment from feed. There has been little research on fertilization of shrimp ponds, but practical experience suggests the following:

- (i) Waters with high concentrations of nitrogen and phosphorus (polluted waters) do not require as much fertilizer as water with low concentrations of these nutrients.
- (ii) Fertilization becomes less important as feeding rates increase.
- (iii) Diatoms are good food organisms for shrimp, and diatoms can be encouraged by adding large amounts of nitrogen fertilizer relative to phosphate fertilizer.
- (iv) High feeding and fertilization rates cause heavy phytoplankton blooms and increase the probability of low DO concentrations.
- (v) Low salinity coupled with high phosphorus concentrations favors blue-green algal blooms.
- (vi) Fertilization and feeding creates turbidity which helps control the growth of underwater weeds.
- (vii) The development of a suitable fertilization schedule for a particular shrimp farm must be done by trial and error, because research findings are inconclusive.
- (viii) Water exchange flushes out fertilizer nutrients.

The food web in a shrimp pond is illustrated in figure 6. Of course, feed may be applied to supplement the natural food.

### Chemical Fertilizers

Inorganic fertilizers are substances which contain nitrogen, phosphorus, and potassium either alone or in combination. Examples of common fertilizer compounds are listed in table 5. When two or more of these materials are blended, the resulting mixture is called a mixed fertilizer. Fertilizers are classified by plant nutrient content; nitrogen is expressed as N, phosphorus pentoxide  $P_2O_5$ , and potash  $K_2O$ .

Nitrogen is present in fertilizers as nitrate ( $\text{NO}_2^-$ ), ammonium ( $\text{NH}_4^+$ ), or urea [ $(\text{NH}_2)_2\text{CO}$ ], phosphorus as phosphate ( $\text{H}_2\text{PO}_4^-$ ), and potassium as potassium ion ( $\text{K}^+$ ). Use of N,  $\text{P}_2\text{O}_5$ , and  $\text{K}_2\text{O}$  is traditional instead of descriptive, i.e., fertilizers do not contain elemental N,  $\text{P}_2\text{O}_5$ , and  $\text{K}_2\text{O}$ .

Table 5. Approximate Grades of Common Commercial Fertilizers

| Substance              | Percentage |                        |                      |
|------------------------|------------|------------------------|----------------------|
|                        | N          | $\text{P}_2\text{O}_5$ | $\text{K}_2\text{O}$ |
| Urea                   | 45         | 0                      | 0                    |
| Calcium nitrate        | 15         | 0                      | 0                    |
| Sodium nitrate         | 16         | 0                      | 0                    |
| Ammonium nitrate       | 33         | 0                      | 0                    |
| Ammonium sulfate       | 21         | 0                      | 0                    |
| Superphosphate         | 0          | 20                     | 0                    |
| Triple superphosphate  | 0          | 46                     | 0                    |
| Monoammonium phosphate | 11         | 48                     | 0                    |
| Diammonium phosphate   | 18         | 48                     | 0                    |
| Ammonium polyphosphate | 10-13      | 34-39                  | 0                    |
| Muriate of potash      | 0          | 0                      | 60                   |

A fertilizer with a grade of 15-15-5 contains 15% N, 15%  $\text{P}_2\text{O}_5$ , and 5%  $\text{K}_2\text{O}$ . The grade of a commercial fertilizer is provided by the vendor. It will be instructive to consider how to make a mixed fertilizer like the 15-15-5 mentioned above. This fertilizer is not necessarily the best for shrimp ponds; it is used here simply for illustration. A 100-kg quantity of mixed 15-15-5 fertilizer will be made of urea, triple superphosphate (TSP), and potassium chloride (KCl). In 100 kg of 15-15-5, there will be 15 kg N, 15 kg  $\text{P}_2\text{O}_5$ , and 5 kg  $\text{K}_2\text{O}$ . Necessary amounts of fertilizer compounds are:

- (i)  $15 \text{ kg N} \div 0.45 \text{ kg N/kg urea} = 33.3 \text{ kg urea}$
- (ii)  $15 \text{ kg } \text{P}_2\text{O}_5 \div 0.46 \text{ kg } \text{P}_2\text{O}_5/\text{kg TSP} = 32.6 \text{ kg TSP}$
- (iii)  $5 \text{ kg } \text{K}_2\text{O} \div 0.60 \text{ kg } \text{K}_2\text{O}/\text{kg KCl} = \underline{8.3} \text{ kg KCl}$
- (iv) Total fertilizer compounds = 74.2 kg
- (v) Filler (agricultural limestone) = 25.8 kg
- (vi) Total = 100.0 kg

Fertilizer compounds must be diluted to 100 kg with filler so that the mixed fertilizer will have the proper N- $\text{P}_2\text{O}_5$ - $\text{K}_2\text{O}$  percentages. This is done by adding a material like agricultural limestone (pulverized

limestone) to the mixture of fertilizer compounds. In the example above, 25.8 kg of agricultural limestone were added as filler.

When granular fertilizers are broadcast over pond surfaces, they settle to the bottom before dissolving completely (12). Phosphate is adsorbed strongly by mud, and much of it never reaches the water. Liquid fertilizers are much more efficient than granular fertilizers, because they will not settle to the bottom (46). Three common liquid fertilizers suitable for aquaculture are liquid urea (45-0-0), phosphoric acid (0-55-0), and ammonium polyphosphate (10-34-0 to 13-39-0). If these materials cannot be purchased locally, suitable liquid fertilizers may be made by dissolving granular fertilizers in a container of water. Liquid fertilizers should be diluted with water and splashed over pond surfaces. In a large pond, liquid fertilizer may be released into the propeller wash of an outboard motor as a boat is driven over the pond surface. It might also be efficient to splash liquid fertilizer into the water that flows into a shrimp pond. Never pour liquid fertilizers directly into pond water, because they are heavier than water and will settle to the bottom.

An alternative means of applying granular fertilizer is to pour it on an underwater platform so that water currents move the nutrients throughout the pond after they dissolve (43). Some workers also put fertilizer in porous bags and suspend these bags in ponds so that nutrients are released to the water as fertilizers dissolve. Either procedure prevents the fertilizer granules from dissolving while in contact with pond bottom soils. Nevertheless, regardless of the technique used for applying fertilizers, the phosphorus is eventually assimilated by plants, adsorbed by pond muds, or lost in outflowing water. Nitrogen is not strongly absorbed by pond muds, but is lost through denitrification and in outflow.

Most pond fertilization research has been conducted in freshwater (13). Application rates usually have consisted of 2 to 9 kg/ha of  $P_2O_5$  alone, or applications of 2 to 9 kg/ha of both N and  $P_2O_5$ . One of the best fertilization programs for freshwater ponds consists of periodic applications of 2 to 4 liters per hectare (1/ha) of a 10-34-0 liquid fertilizer (11, 13). This amounts to 3.9 to 7.8 kg/ha of  $P_2O_5$  and 1.1 to 2.2 kg/ha of N. Fertilizer applications normally are made at 3- to 4-week intervals.

Nitrogen is more important as a limiting factor in brackishwater ponds than in freshwater ponds. Furthermore, a wide N:P ratio is thought to encourage the growth of diatoms (6). For these reasons, a fertilization program for brackishwater ponds should employ more nitrogen and less phosphorus than recommended for freshwater ponds. In a recent experiment (Daniels and Boyd, unpublished data), fertilization with 30 kg N/ha and 1 kg P/ha (2.29 kg  $P_2O_5$ /ha) or 15 kg N/ha and 1 kg P/ha (2.29 kg  $P_2O_5$ /ha) resulted in good phytoplankton blooms that consisted of 50% to 90% diatoms. Both urea and sodium nitrate were suitable as nitrogen sources. Ammonium chloride did not perform well. Triple superphosphate was used as a source of phosphorus. The water was low in silica (<1 mg/l), and additions of silicate at 30 kg Si/ha per application with N:P ratios of 30:1 or 15:1 further enhanced the

production of diatoms. The general benefits of silica fertilization is unknown. Experiments on silica fertilization might prove valuable. However, silica concentrations are fairly high in brackishwater in most tropical nations.

The ideal frequency of fertilization for shrimp ponds is not known. However, if water exchange rates of 5 to 10% per day are used, fertilization two or more times per week is needed. Water exchange flushes nutrients and plankton from ponds and counteracts fertilization. When ponds are first stocked with shrimp, applying fertilizers once or twice weekly and limiting water exchange is suggested. If feed is not applied to ponds and waters are infertile, heavy fertilization must be continued until shrimp are harvested. However, if feed is applied, feeding rates will gradually increase as the standing crop of shrimp increases, and nitrogen and phosphorus from the feed will supplement the fertilizer. Therefore, fertilizer applications may be reduced and possibly discontinued as feeding rates increase. Heavy plankton blooms result from excessive nitrogen and phosphorus concentrations, and can cause DO depletion.

Much is unknown about fertilization of shrimp ponds, so the shrimp farmer may use the suggestions presented as a basis for developing experimental fertilization programs. Different fertilizers, N:P ratios, application rates, and frequencies of application may be tested in production ponds until a suitable fertilization program is found. For those who do not desire to experiment, a 20:1 ratio of N:P is suggested. Infertile waters need 20 kg N/ha and 1 kg P/ha two or more times per week. Where waters are more fertile, the amounts may be reduced by 50% or more, but the 20:1 ratio of N:P should be maintained in brackishwater. Fertilization should be suspended when plankton blooms become dense during periods of heavy feed applications.

Fertilizers should be used with caution to prevent excessive plankton blooms. Once Secchi disk visibility is less than 30 to 40 cm, fertilizers should be applied less frequently and in smaller doses. However, fertilizer applications should not be reduced to the point that plankton blooms disappear. Where feeding is employed, fertilizer applications will probably not be required after feeding rates reach 20 or 30 kg/ha per day.

I have by convention reported the phosphorus content of fertilizers in terms of  $P_2O_5$ , but I gave N:P ratios. To convert from  $P_2O_5$  to P, divide by 2.29. For example, 46%  $P_2O_5$  is  $46 \div 2.29 = 20.1\%$  P.

Suppose that one desires to calculate the amounts of urea and triple superphosphate required to provide 20 kg N/ha and 1 kg P/ha in a 15-ha pond. From table 5, urea is 45% N and 0% P and triple superphosphate is 0% N and 46%  $P_2O_5$  (or  $46\% \div 2.29 = 20.1\%$  P). The amounts are calculated as follow:

$$(20 \text{ kg N/ha} \div 0.45 \text{ kg N/kg urea}) \times 15 \text{ ha} = 667 \text{ kg urea}$$

$$(1 \text{ kg P/ha} \div 0.201 \text{ kg P/kg triple superphosphate}) \times 15 \text{ ha} = 75 \text{ kg triple superphosphate}$$

## Manures

Manures are animal excrements and other agricultural wastes. Manures are largely organic matter, but they contain some nitrogen, phosphorus, and potassium, table 6. It takes a large quantity of manure to give the same amounts of fertilizer nutrients found in a small quantity of inorganic fertilizer. For example, on a dry weight basis, 100 kg of poultry manure contains about 1.2 kg nitrogen (100 kg x 0.012). Urea is 45% nitrogen, and 2.67 kg of urea would contain as much nitrogen as 100 kg of poultry manure ( $1.2 \div 0.45 = 2.67$  kg). Nevertheless, in some places manures are readily available and cheaper than inorganic fertilizers.

Table 6. Fertilizer Constituents in Fresh Manure of Selected Farm Animals

| Manure       | Average composition, pct. |     |                               |                  |
|--------------|---------------------------|-----|-------------------------------|------------------|
|              | Moisture                  | N   | P <sub>2</sub> O <sub>5</sub> | K <sub>2</sub> O |
| Dairy cattle | 85                        | 0.5 | 0.2                           | 0.5              |
| Beef cattle  | 85                        | .7  | .5                            | .5               |
| Poultry      | 72                        | 1.2 | 1.3                           | .6               |
| Swine        | 82                        | .5  | .3                            | .4               |
| Sheep        | 77                        | 1.4 | .5                            | 1.2              |

When manures are applied to ponds, they decay and release inorganic nutrients which can be used by phytoplankton (13). Because manures have an oxygen demand, the shrimp farmer must be careful not to apply enough to cause an oxygen depletion. Manure also serves as food for zooplankton, shrimp, and fish, but it is low in protein and cannot be considered a high quality food. The combination of manure and inorganic fertilizer sometimes is used to stimulate zooplankton blooms in ponds.

Larger quantities of manures must be applied to ponds because they are not concentrated sources of plant nutrients. Many times, initial applications of 500 to 1,000 kg/ha of fresh manure are made to ponds, followed by applications of 200 to 300 kg/ha at 1- to 2-week intervals. Manures have high C/N ratios and little phosphorus, so they do not decompose rapidly. Some aquaculturists apply inorganic fertilizer to enhance the nutrient supply and hasten decomposition of manure. In manured ponds, particles of manure on the pond bottom or suspended in water provide a substrate for microbial growth. Bacteria enhance the protein content of manure particles and improve the nutritive value of particles for shrimp food. Zooplankton feed directly on particles of manure, and manuring is an effective procedure for rapidly increasing zooplankton abundance.

Some shrimp farmers initially fill their ponds with only a small volume of water (10 to 20% total capacity) and apply a large amount of chicken manure. After a few days a heavy plankton bloom develops. Water then is added slowly over a few days to fill the pond. This procedure assures abundant plankton to serve as food for young shrimp.

### DISSOLVED OXYGEN

Dissolved oxygen is the most critical water quality variable in aquaculture. Aquaculturists need a thorough understanding of factors affecting the concentration of DO in pond water. They also should be aware of the influence of low DO concentrations on aquatic organisms.

#### Solubility

The atmosphere contains 20.95% oxygen (33). At standard barometric pressure, 760 millimeters (mm) of mercury, the pressure of oxygen in air is 159.2 mm ( $760 \times 0.2095$ ). The pressure of oxygen in air varies with barometric pressure. Elevation has a marked effect on barometric pressure; pressure decreases with increasing elevation. At a given location, barometric pressure varies during the day and from day to day. Local variation in barometric pressure seldom is more than 5% above or below normal barometric pressure. Shrimp ponds are in low-lying coastal areas, so elevation is near sea level. Therefore, for practical purposes, one may assume that barometric pressure acting on surfaces of shrimp ponds is 760 mm and that the pressure of oxygen in air above shrimp ponds is 159.2 mm.

The pressure of oxygen in air drives oxygen into water until the pressure of oxygen in water is equal to the pressure of oxygen in air. When the pressure of oxygen in water and air are equal, net movement of oxygen molecules from air to water ceases. When this occurs, DO is said to be at equilibrium, or at saturation. The concentration of DO at saturation varies with barometric pressure, temperature, and salinity. As already mentioned, the effect of barometric pressure will be ignored because it will be small for water in shrimp ponds. As water temperature or salinity increase, the DO concentration at saturation decreases, table 7. At 25°C and 0 ppt salinity, the DO concentration at saturation is 8.24 mg/l. If temperature increases to 30°C with no change in salinity, the DO concentration at saturation drops to 7.54 mg/l. The DO concentration at saturation is 6.39 mg/l for 30 ppt salinity and 30°C.

Plants growing in pond water produce oxygen by photosynthesis, and during daylight, plants may produce oxygen so fast that DO concentrations in water rise above saturation. Water containing more DO than expected for the existing barometric pressure, water temperature, and salinity is said to be supersaturated with DO.

Water also may contain less DO than expected at saturation for prevailing conditions. Respiration by organisms in ponds may cause DO levels to decline; DO typically declines at night.

Table 7. The Solubility of Oxygen in mg/L as Functions of Temperature and Salinity 0-40 ppt (Moist Air, Barometric Pressure = 760 mm Hg)

| Temp<br>(c) | Salinity, parts per thousand (ppt) |       |       |       |       |       |       |       |       |
|-------------|------------------------------------|-------|-------|-------|-------|-------|-------|-------|-------|
|             | 0                                  | 5     | 10    | 15    | 20    | 25    | 30    | 35    | 40    |
| 0           | 14.60                              | 14.11 | 13.64 | 13.18 | 12.74 | 12.31 | 11.90 | 11.50 | 11.11 |
| 1           | 14.20                              | 13.72 | 13.27 | 12.82 | 12.40 | 11.98 | 11.58 | 11.20 | 10.82 |
| 2           | 13.81                              | 13.36 | 12.91 | 12.49 | 12.07 | 11.67 | 11.29 | 10.91 | 10.55 |
| 3           | 13.44                              | 13.00 | 12.58 | 12.16 | 11.76 | 11.38 | 11.00 | 10.64 | 10.29 |
| 4           | 13.09                              | 12.67 | 12.25 | 11.85 | 11.47 | 11.09 | 10.73 | 10.38 | 10.04 |
| 5           | 12.76                              | 12.34 | 11.94 | 11.56 | 11.18 | 10.82 | 10.47 | 10.13 | 9.80  |
| 6           | 12.44                              | 12.04 | 11.65 | 11.27 | 10.91 | 10.56 | 10.22 | 9.89  | 9.57  |
| 7           | 12.13                              | 11.74 | 11.36 | 11.00 | 10.65 | 10.31 | 9.98  | 9.66  | 9.35  |
| 8           | 11.83                              | 11.46 | 11.09 | 10.74 | 10.40 | 10.07 | 9.75  | 9.44  | 9.14  |
| 9           | 11.55                              | 11.18 | 10.83 | 10.49 | 10.16 | 9.84  | 9.53  | 9.23  | 8.94  |
| 10          | 11.28                              | 10.92 | 10.58 | 10.25 | 9.93  | 9.62  | 9.32  | 9.03  | 8.75  |
| 11          | 11.02                              | 10.67 | 10.34 | 10.02 | 9.71  | 9.41  | 9.12  | 8.83  | 8.56  |
| 12          | 10.77                              | 10.43 | 10.11 | 9.80  | 9.50  | 9.21  | 8.92  | 8.65  | 8.38  |
| 13          | 10.52                              | 10.20 | 9.89  | 9.59  | 9.29  | 9.01  | 8.73  | 8.47  | 8.21  |
| 14          | 10.29                              | 9.98  | 9.68  | 9.38  | 9.10  | 8.82  | 8.55  | 8.29  | 8.04  |
| 15          | 10.07                              | 9.77  | 9.47  | 9.19  | 8.91  | 8.64  | 8.38  | 8.13  | 7.88  |
| 16          | 9.86                               | 9.56  | 9.28  | 9.00  | 8.73  | 8.47  | 8.21  | 7.97  | 7.73  |
| 17          | 9.65                               | 9.36  | 9.09  | 8.82  | 8.55  | 8.30  | 8.05  | 7.81  | 7.58  |
| 18          | 9.45                               | 9.17  | 8.90  | 8.64  | 8.38  | 8.14  | 7.90  | 7.66  | 7.44  |
| 19          | 9.26                               | 8.99  | 8.73  | 8.47  | 8.22  | 7.98  | 7.75  | 7.52  | 7.30  |
| 20          | 9.08                               | 8.81  | 8.56  | 8.31  | 8.06  | 7.83  | 7.60  | 7.38  | 7.17  |
| 21          | 8.90                               | 8.64  | 8.39  | 8.15  | 7.91  | 7.68  | 7.46  | 7.25  | 7.04  |
| 22          | 8.73                               | 8.48  | 8.23  | 8.00  | 7.77  | 7.54  | 7.33  | 7.12  | 6.91  |
| 23          | 8.56                               | 8.32  | 8.08  | 7.85  | 7.63  | 7.41  | 7.20  | 6.99  | 6.79  |
| 24          | 8.40                               | 8.16  | 7.93  | 7.71  | 7.49  | 7.28  | 7.07  | 6.87  | 6.68  |
| 25          | 8.24                               | 8.01  | 7.79  | 7.57  | 7.36  | 7.15  | 6.95  | 6.75  | 6.56  |
| 26          | 8.09                               | 7.87  | 7.65  | 7.44  | 7.23  | 7.03  | 6.83  | 6.64  | 6.46  |
| 27          | 7.95                               | 7.73  | 7.51  | 7.31  | 7.10  | 6.91  | 6.72  | 6.53  | 6.35  |
| 28          | 7.81                               | 7.59  | 7.38  | 7.18  | 6.98  | 6.79  | 6.61  | 6.42  | 6.25  |
| 29          | 7.67                               | 7.46  | 7.26  | 7.06  | 6.87  | 6.68  | 6.50  | 6.32  | 6.15  |
| 30          | 7.54                               | 7.33  | 7.14  | 6.94  | 6.75  | 6.57  | 6.39  | 6.22  | 6.05  |
| 31          | 7.41                               | 7.21  | 7.02  | 6.83  | 6.64  | 6.47  | 6.29  | 6.12  | 5.96  |
| 32          | 7.29                               | 7.09  | 6.90  | 6.72  | 6.54  | 6.36  | 6.19  | 6.03  | 5.87  |
| 33          | 7.17                               | 6.98  | 6.79  | 6.61  | 6.43  | 6.26  | 6.10  | 5.94  | 5.78  |
| 34          | 7.05                               | 6.86  | 6.68  | 6.51  | 6.33  | 6.17  | 6.01  | 5.85  | 5.69  |
| 35          | 6.93                               | 6.75  | 6.58  | 6.40  | 6.24  | 6.07  | 5.91  | 5.76  | 5.61  |
| 36          | 6.82                               | 6.65  | 6.47  | 6.31  | 6.14  | 5.98  | 5.83  | 5.68  | 5.53  |
| 37          | 6.72                               | 6.54  | 6.37  | 6.21  | 6.05  | 5.89  | 5.74  | 5.59  | 5.45  |
| 38          | 6.61                               | 6.44  | 6.28  | 6.12  | 5.96  | 5.81  | 5.66  | 5.51  | 5.37  |
| 39          | 6.51                               | 6.34  | 6.18  | 6.02  | 5.87  | 5.72  | 5.58  | 5.44  | 5.30  |
| 40          | 6.41                               | 6.25  | 6.09  | 5.94  | 5.79  | 5.64  | 5.50  | 5.36  | 5.22  |

When water is below saturation with DO, there is a net movement of oxygen molecules from air to water. At saturation with DO, the number of oxygen molecules leaving the water equals the number entering; there



is no net movement of oxygen molecules. Net movement of oxygen molecules from water to air occurs when water is supersaturated with DO. The larger the difference between the pressure of oxygen in water and air, the greater the movement of oxygen molecules.

The degree of saturation of water with DO frequently is expressed as percent saturation. The equation for estimating percentage saturation is:

$$\% \text{ Saturation} = \frac{\text{DO concentration in water}}{\text{DO concentration at saturation}} \times 100$$

For example, suppose that pond water with 20 ppt salinity at 28°C contains 4 mg/l of DO. To estimate percent saturation, look up the oxygen saturation value for 28°C and 20 ppt salinity in table 7. The value is 6.98 mg/l, and the percent saturation is:

$$\% \text{ Saturation} = \frac{4}{6.98} \times 100 = 57.3\%$$

If water at the same temperature and pressure mentioned above contained 8.5 mg/l DO instead of 4 mg/l DO, percent saturation would be:

$$\% \text{ Saturation} = \frac{8.5}{6.98} \times 100 = 121.8\%$$

### Effects of DO on Shrimp

The influence of DO concentrations on shrimp and fish (13) cultured in ponds is summarized below:

| <u>DO concentration</u> | <u>Effect</u>  |
|-------------------------|--|
| Less than 1 mg/l        | Lethal if exposure lasts more than a few hours.  |
| 1-5 mg/l                | Growth will be slow if exposure to low Do is continuous.   |
| 5 mg/l-saturation       | Best condition for good growth.  |
| Above saturation        | Can be harmful if supersaturated conditions exist throughout pond volume. Normally, there is no problem. |

Concentrations of DO can fall so low that shrimp in ponds are killed. However, adverse effects of low DO more often are expressed as reduced growth and greater susceptibility to disease. In ponds with chronically low DO concentrations, fish will eat less and they will not convert food to flesh as efficiently as in ponds with normal DO concentrations (5, 13, 42). The same relationship to DO probably is exhibited by shrimp.

## Fluctuations in DO Concentrations

Light passing through pond water is rapidly quenched, and the rate of quenching increases as the amount of particulate matter (turbidity) in the water increases. Therefore, plankton blooms reduce light penetration, and the heavier the bloom the less light available for photosynthesis at a given depth. As a result, photosynthesis occurs most rapidly in the surface layer of water, and DO concentrations decline with depth (8, 13, 40). In deep ponds, DO concentrations may fall to 0 mg/l at depths of 1.5 or 2 m, figure 7. The rate at which DO declines with depth increases with greater turbidity; in ponds, phytoplankton often is the major source of turbidity (3). For this reason, it is advantageous to have shallow ponds (75 to 150 cm deep). It is especially important to have fairly shallow ponds for shrimp, because they dwell primarily on the bottom, and low DO concentrations at the pond bottom would be especially harmful.

Concentrations of DO exhibit a daily cycle. The lowest concentrations of DO occur at dawn. During daylight, photosynthesis causes DO concentrations to increase, and maximum DO concentrations are reached in the afternoon. During the night, photosynthesis ceases and respiration by organisms in the pond consumes oxygen and causes DO concentrations to fall. The daily cycle in DO is most pronounced in ponds with heavy phytoplankton blooms, figure 8. The DO cycle shown in figure 8 is for surface water. However, studies of shrimp ponds in Ecuador (Daniels and Boyd, unpublished data) revealed that DO concentrations at the pond bottom exhibit the same cycle. Of course, light intensity at the pond bottom is less than at the pond surface, and DO concentrations sometimes are lower at the bottom than at the surface. The influence of the daily cycle of DO on growth of aquaculture species is poorly understood, but most workers feel that good growth can be achieved as long as the DO concentration does not fall below 25 or 30% of saturation during the night and does not remain at this low level for more than 1 or 2 hours (13). The procedure outlined in figure 9 may be used to determine how low DO will fall in a pond during the night (24).

Cloudy weather profoundly influences DO concentrations as illustrated in figure 10. This results because DO concentrations do not increase as much on a cloudy day as on a clear day, but just as much oxygen is consumed at night by the pond biota. The influence of cloudy weather is more pronounced in a pond with a heavy phytoplankton bloom than in a pond with less phytoplankton.

Phytoplankton in ponds may suddenly die and decompose, causing DO depletion (7, 23). An example of a phytoplankton die-off is shown in figure 11, and the influence of the die-off on DO concentrations is illustrated in figure 12. The DO concentrations did not return to normal until a new phytoplankton bloom was established. Most phytoplankton die-offs involve species of blue-green algae. During calm weather, blue-green algae often form scums at pond surfaces. Intense sunlight may result in sudden death of algae in this scum. Blue-green algae have high concentrations of nitrogen in their tissue, so they decompose rapidly.

Mats of filamentous algae which develop on pond bottoms may, under certain conditions, float to the surface of a pond and die (35). This phenomenon also can cause depletion of DO.

Water supply canals for shrimp farms in some countries are polluted with organic substances. On occasion, unusually large quantities of organic matter enter canals. If highly polluted water is pumped into ponds, decomposition of organic matter by bacteria may cause DO depletion.

### Feeding and DO

It already has been shown that phytoplankton abundance is controlled by nutrient supply, and that DO concentrations are regulated to a large extent by phytoplankton abundance. Feed applied for shrimp results in pollution of pond waters by organic and inorganic metabolic wastes from shrimp. Uneaten feed also decomposes, releasing nutrients into the water. Consequently, phytoplankton abundance increases as a function of increasing feeding rate. As phytoplankton abundance increases, the daily cycle in DO becomes more extreme. Concentrations of DO at dawn are lower and concentrations of DO in the afternoon are higher, figure 8. Additionally, DO concentrations decline more rapidly with depth as phytoplankton abundance increases in response to higher feeding rates, figure 7. If phytoplankton blooms are extremely dense, DO may be low on pond bottoms, even in ponds where the water depth does not exceed 1 m. The probability of DO depletion during cloudy weather and the likelihood of phytoplankton die-offs are greater in ponds with high feeding rates and abundant phytoplankton (54).

The influence of feeding rate on DO concentrations is illustrated in figures 13 and 14. These data suggest that feeding rates above 40 or 50 kg/ha per day will result in unacceptably low DO. Higher feeding rates may be used in ponds if aeration is applied. Aeration is discussed in another section.

Feeding is a proven technique for increasing production. However, feeding results in deterioration of water quality, in greater phytoplankton abundance, and in lower DO concentrations during the night. If feeds are applied in excessive quantity, DO depletion can result in mortality of shrimp.

Feed conversion value is determined as the quantity of feed applied divided by the weight of shrimp harvested. For example, suppose that a 1-ha pond yielded 1,600 kg of shrimp and 3,100 kg of feed had been applied. The feed conversion value is:

$$\frac{3,100 \text{ kg feed}}{1,600 \text{ kg shrimp}} = 1.94.$$

A low feed conversion value indicates greater efficiency than a high value. With good management practices, feed conversion values of 1.5 to 2.0 may be achieved with many species of fish. With shrimp, feed

conversion values less than 2.0 can be achieved at low feeding rates. However, in highly intensive shrimp production, feed conversion values usually are between 2.0 and 3.0. One of the effects of overfeeding in shrimp ponds is to increase the feed conversion value. Notice that a low feed conversion value indicates better use of feed by shrimp than a high value. As feeding rate increases, DO concentrations during the night decline. Chronically low DO concentrations have an adverse effect on the appetite and metabolism of shrimp, and feed conversion values tend to increase drastically if feeding rates are increased to a level where DO concentrations fall below 2 or 3 mg/l each night.

### Oxygen Budgets

Inputs and outputs of oxygen over an 8-month period were determined for three channel catfish ponds in Alabama (16). These ponds were 1 m average depth and had maximum daily feeding rates of 45 kg/ha per day. Water exchange was not practiced, but emergency aeration was used on several occasions in each pond. The budget which is presented below is instructive even to those interested only in shrimp ponds:

| <u>Item</u>                          | <u>Dissolved oxygen</u> |             |
|--------------------------------------|-------------------------|-------------|
|                                      | <u>kg/ha</u>            | <u>pct.</u> |
| <u>Input</u>                         |                         |             |
| Photosynthesis                       | 4,130                   | 76.9        |
| Inflowing water                      | 94                      | 1.7         |
| Aeration                             | 99                      | 1.8         |
| Diffusion (net)                      | <u>1,050</u>            | <u>19.6</u> |
|                                      | 5,373                   | 100.0       |
| <u>Output</u>                        |                         |             |
| Overflow and draining of water       | 32                      | 0.6         |
| Phytoplankton respiration            | 3,090                   | 57.5        |
| Respiration by organisms in sediment | 1,040                   | 19.4        |
| Fish respiration                     | <u>1,210</u>            | <u>22.5</u> |
|                                      | 5,372                   | 100.0       |

Most of the oxygen (76.9%) was derived from photosynthesis by phytoplankton, and most of the oxygen produced by phytoplankton was consumed in respiration by these same organisms. Respiration by fish accounted for only 22.5% of the total output of oxygen.

Oxygen budgets are not available for shrimp ponds, but shrimp ponds receive more oxygen in inflowing water than catfish ponds because of water exchange. For the same reason, more oxygen would be lost from shrimp ponds in outflowing water. Respiration in sediment also would be somewhat greater in many shrimp ponds than in catfish ponds because many shrimp ponds receive large amounts of organically enriched sediment. In shrimp ponds, both phytoplankton and water exchange will be dominant factors in the oxygen budget, and in some ponds benthic respiration also will be quite important.

## AERATION

### Aerators

Aerators are mechanical devices that increase the rate at which oxygen enters water. There are two basic techniques for aerating pond water: water is splashed into the air or bubbles of air are released into the water (18). Hence, we have "splasher" and "bubbler" aerators.

Splasher aerators include vertical pump, pump-sprayer, and paddle wheel aerators. A vertical pump aerator consists of a motor with an impeller (propeller) attached to its shaft. The motor is suspended below a float with a center opening and the impeller jets water into the air at low velocity, figure 15. A pump-sprayer aerator employs a centrifugal pump to spray water at high velocity through holes in a manifold and into the air, figure 16. A paddle wheel aerator splashes water into the air as the paddle wheel rotates, figure 17.

Bubbler aerators include diffused-air systems and propeller-aspirator-pumps. In a diffused-air system, an air blower or air compressor is employed to deliver air through an air line, and the air is released through air diffusers located on the pond bottom or suspended in the water, figure 18. The propeller-aspirator-pump aerator has a high velocity, uncased impeller at the end of a hollow shaft and housing. In operation, air flows down the shaft by the venturi principle and is released into the water in fine bubbles, figure 19.

Aerators usually are powered by electric motors. Where electricity is unavailable, aerators may be driven by the power-take-off (PTO) of farm tractors or by diesel or gasoline engines.

Boyd and Ahmad (18) evaluated more than 30 aerators for aquaculture. The oxygen transfer efficiencies of the aerators in kilograms of oxygen transferred per kilowatt-hour of power applied to aerator shafts is presented below for the basic types of aerators:

| <u>Type of aerator</u>    | <u>Average oxygen transfer efficiency</u> |
|---------------------------|---|
|                           | <u>kg O<sub>2</sub>/kw·hr</u>             |
| Paddle wheels             | 2.13                                      |
| Propeller-aspirator-pumps | 1.58                                      |
| Vertical pumps            | 1.28                                      |
| Pump sprayers             | 1.28                                      |
| Diffused air systems      | 0.97                                      |

The purchase prices of different types of aerators do not differ greatly per kilowatt of motor size. Therefore, paddle wheel aerators will transfer oxygen to pond water at a lower cost than other types of aerators. However, all types of aerators have been used successfully in aquaculture.

The standard aeration efficiency (SAE) of an aerator is a measure of the amount of oxygen that an aerator will transfer to water under standard conditions of 20°C, 0 mg/l DO, and clean, freshwater. These conditions seldom exist in shrimp ponds, and the aerator will transfer

less oxygen to pond water than it will transfer under standard conditions (18, 56). Nevertheless, SAE values permit one to compare the efficiencies of different aerators.

Salinity has little effect on oxygen-transfer efficiency of aerators (19). However, water with high salinity is corrosive. Therefore, aerators for salt water must be protected from corrosion. It is possible, but expensive, to use stainless steel or plastic construction. An alternative is to use mild steel construction and employ a hot-dip galvanization procedure to coat the steel with a layer of corrosion-resistant material. After the galvanized surfaces have aged for about 6 months, a coat of epoxy paint over the galvanized surfaces will afford further protection against corrosion. Some aquaculturists have used coal-tar epoxy paint over mild steel to retard corrosion. Methods of corrosion prevention have not been tested, and work in this area is needed.

### **Paddle Wheel Aerator Design**

In an extensive study of design and performance of floating, electric, paddle wheel aerators (1), it was found that the best design for a paddle wheel consisted of a 90-cm-diameter paddle wheel with paddles triangular (135° interior angle) in cross section. The width of paddles is unimportant from the standpoint of oxygen transfer. However, fabrication of a paddle wheel with wide paddles (10 to 15 cm) is easier than for one with narrow paddles, because fewer paddles have to be made and welded to the hub. There were four paddles per row around the circumference of the hub, and the paddles were attached in a pattern which provided a spiral arrangement, figure 20. With the spiral of paddles, a constant paddle area moves through the water and the torque necessary to turn the paddle wheel is relatively constant. Torque constantly changes with other paddle arrangements. Paddle depth should be 10 to 15 cm, and paddle wheel speed should be about 80 to 90 rpm. The paddle wheel requires approximately 1 kw of power for each 50 cm of paddle wheel length. Of course, power requirements vary with paddle wheel speed and paddle depth.

The paddle wheel design described above is ideal for paddle wheel aerators of 2 to 10 kw. For smaller paddle wheel aerators, it is more convenient to reduce the diameter of the paddle wheel from 90 cm to about 60 cm and to use paddles of 5-cm width.

Power requirement for a paddle wheel aerator of a given diameter increases linearly, with increasing speed and with increasing paddle depth (1, 22). For a particular speed and paddle depth, the power requirement increases linearly as paddle wheel diameter increases. The oxygen transfer efficiency of paddle wheel aerators is related to paddle tip speed. Paddle wheels of 50, 70, and 90 cm diameter and 12.5 cm paddle depth were run at different speeds. The greatest aeration efficiencies were achieved at 80 rpm for the 90-cm-diameter paddle wheel, at 105 rpm for the 70-cm-diameter paddle wheel, and at 130 rpm for the 50-cm-diameter paddle wheel. Paddle tip speeds (angular velocities of tips) were similar at optimum speeds (50 cm, 3.5 m/sec; 70 cm, 3.9 m/sec; 90 cm, 3.8 m/sec). The 90-cm-diameter paddle wheel had a

greater oxygen-transfer efficiency than the two smaller diameter paddle wheels. The power requirements for a paddle wheel with a specific combination of diameter, depth, and speed will increase in direct proportion to paddle wheel length. However, for small paddle wheel aerators (2 kw and less), it is not practical to use a 90-cm-diameter paddle wheel because it would be too short. It is probably best to make the paddle wheel 1 m or 1.5 m long, but only 60 cm in diameter, for small aerators. The load can be adjusted to the motor size by regulating the depth of paddles.

Several aerator manufacturers have taken the paddle wheel aerator design described above and used it, or a slight modification of it, to fabricate floating, electric, paddle wheel aerators powered by 2.25- to 7.5-kw electric motors. A 7.5-kw electric paddle wheel aerator is shown in figure 21. The aerator had a 3.66-m-long by 20-cm-diameter hub made of steel tubing. A short, 5.08-cm-diameter shaft was welded to each of two circular plates (20-cm-diameter), and the plate and shaft were welded to each end of the hub. Paddles were made of 0.32-cm-thick, 35.6-cm-long, by 15-cm-wide steel plates. The paddles were placed in a brake press and bent along the centers of their long axes to provide a rectangular cross section ( $135^\circ$  interior angle). Paddles were welded directly to the hub. There were four paddles welded  $90^\circ$  apart in each row around the circumference of the hub. Paddles were positioned in spiral fashion on the hub; the first paddle in each row was offset  $15^\circ$  from the first paddle in the preceding row of paddles to produce the spiral. A total of 24 rows of paddles (96 paddles) was attached to the hub. The paddle wheel was mounted in pillar block bearings, and the bearings were attached to the steel frame. Four 200-l barrels were filled with styrofoam and used for flotation. Two barrels were attached with straps and turnbuckles to each end of the frame. By adjusting the turnbuckles, the frame and paddle wheel could be leveled and the paddle depth adjusted. A 7.5-kw, 230/460-volt, 3-phase electric gear motor was bolted to one end of the frame. The output shaft of the gear motor was connected to one end of the paddle wheel shaft with a flexible coupling. The paddle wheel aerator was rotated at 88 rpm and the paddle depth was approximately 9 cm. The aerator was maintained in position in a pond by use of two 6-m-long steel pipes (3.8-cm-diameter) attached between the aerator frame and steel posts driven into the pond bank.

A 2.25-kw electric paddle wheel aerator is shown in figure 22. The aerator is constructed in the same manner as the 7.5-kw aerator described above, but it is smaller. The paddle wheel is 90 cm in diameter and approximately 1 m long.

Variation in steel paddle wheel aerator design among manufacturers is not great. Most manufacturers use paddles with a triangular cross section, but paddles rectangular in cross section (channel iron) have been successful. Paddle wheel length and diameter vary slightly among manufacturers. For 7.5-kw units, length varies from 3.05 to 3.66 m and diameter from 80 to 90 cm. Paddle wheel speed varies from 78 to 90 rpm among different brands of steel, electrically powered aerators. Of course, the paddle depth must be adjusted so that the electric motor is properly loaded. It is important to check the amount of current (amperes) used during paddle wheel operation; it is wasteful to run the

motor much below the rated current draw, and a current overload will cause the motor to overheat and "burn out." Use of plastic or metal barrels for flotation permits the use of turnbuckles to adjust paddle depth. However, some manufacturers use styrofoam blocks for flotation and attach the blocks directly to the aerator frame. This arrangement necessitates the use of bearings with vertical adjustment, "take-up bearings" so that paddle depth can be adjusted. Gear motors are convenient, but some manufacturers use a separate motor and gear reducer. The gear reducer is driven by a belt and pulley system, and the output shaft from the gear reducer housing is attached by flexible coupling to the aerator shaft.

It is possible to mount the power unit for paddle wheel aerators on the pond bank, figure 23. This paddle wheel is mounted on floats, but the motor and jackshafts for speed reduction are placed on the pond bank. The paddle wheel is driven by a long shaft which is connected by universal joints to the second jackshaft and to the aerator shaft. This is an excellent design, provided it is not necessary to move the paddle wheel aerator within the pond. This driver mechanism would be especially useful for gasoline or diesel power units.

Paddle wheel aerators may be powered by hydraulic pumps. A hydraulic pump positioned on the pond bank is connected to aerators through hydraulic lines. Several aerators can be operated from a single power unit. Unfortunately, because of excessive maintenance costs, hydraulic systems have not been popular.

Paddle wheel aerators may be constructed of plastic. The popular "Taiwanese paddle wheel" is familiar to most aquaculturists, figure 24. A Japanese firm manufactures a paddle wheel aerator similar to the Taiwanese model.

A company in the United States has been working with Auburn University to develop a paddle wheel aerator constructed of polyurethane plastic. The prototype aerator is shown in figure 25. The hub was made from a solid piece of polyurethane (20 cm in diameter by 1 m long) with stainless steel shafts attached. The polyurethane paddles were attached to threaded polyurethane rods and screwed into tapped holes in the hub. Paddle wheel diameter was 60 cm. Hubs were inserted into bearings made of solid polyurethane. Power was provided by a 0.75-kw gear motor, and the paddle wheel turned at 88 rpm. The frame was made of polyurethane bars attached with brass bolts and screws. The flotation system consisted of plastic barrels.

Where electricity is not available at ponds, aerators may be powered by PTOs of farm tractors. These aerators are not highly energy efficient, but they are useful in an emergency. A typical PTO paddle wheel aerator is shown in figure 26. The aerator was mounted on a trailer fabricated from 9-cm and 10-cm-diameter steel pipe. The paddle wheel hubs were 46-cm-diameter by 46-cm-long pieces of steel tubing. Twelve 36-cm-long by 15-cm-wide by 0.32-cm-thick paddles of slightly concave cross section were welded to each hub. There were four paddles, each 90° apart, in each row of paddles around the hub. The middle row of paddles was rotated 45° on the circumference of a hub to the other



two rows to provide a staggered arrangement of paddles. The hubs and attached paddles were attached on the axles of a truck differential. A 1.95-cm-diameter drive shaft, supported by bearings which were attached to the trailer, was connected at one end to the differential and fitted at the other end with a PTO shaft. Speed reduction by the differential was 4.5:1; this provided a paddle wheel speed of 120 rpm when the tractor PTO was operated at 540 rpm. The overall length of the trailer was 6.86 m and the center of the paddle wheel was 1 m above ground level. This particular paddle wheel can be operated by tractors of 30 kw and larger.

Considerable variation in PTO paddle wheel design has been used. Paddle width has varied from 5 cm to 20 cm; paddles have been flat, triangular, rectangular or flat in cross section. Various patterns of paddle positions around the hub have been used. Diameters of paddle wheels (paddle tip to paddle tip) have varied from 60 to 150 cm. Hub lengths and rows of paddles per hub have varied tremendously. Gear boxes have been used instead of automotive differentials for speed reduction. Hydraulic cylinders have been inserted into the trailer frame to permit the paddle wheel to be raised or lowered without changing the position of the trailer.

#### Aeration of Ponds

It is common to aerate ponds when DO concentrations are low; this practice is called emergency aeration. Pond managers check DO concentrations during the night, and when DO concentrations are expected to fall below 2 to 4 mg/l, emergency aeration is initiated (13). At feeding rates above 40 or 50 kg/ha per day, aeration may be needed frequently. Practical experience indicates that shrimp stress and mortality can be prevented by emergency aeration (25).

It is well known that aeration will increase shrimp production, but there are few data on aeration of shrimp ponds. There is, however, much information on aeration of channel catfish ponds. The author has visited many shrimp farms in Panama, Guatemala, Australia, Ecuador, and Thailand. Relationships among feeding, dissolved oxygen, and shrimp production are almost identical in general features to these relationships in catfish production. Therefore, information that follows on catfish pond aeration should be applicable to shrimp ponds. However, there are major differences which must be considered. Some shrimp ponds are large (20 ha or more); catfish ponds seldom exceed 8 ha in area. Catfish readily swim to the oxygenated zone around aerators. It is not known if shrimp will respond in like manner. Shrimp spend much time at pond bottoms, so DO concentrations at pond bottoms are more critical in shrimp ponds than in catfish ponds.

Aeration may also be applied on a continuous or on a nighttime basis. In an experiment with continuous diffused-air aeration, catfish production was increased from 2,700 kg/ha in control ponds to 5,500 kg/ha in aerated ponds (45). Parker (48) used several types of aeration in small ponds to increase channel catfish production from 3,000 kg/ha in control ponds to 15,000 kg/ha in aerated ponds. In another experiment, the combination of continuous aeration with vertical pump

aerators at 2.5 kw/ha, emergency aeration with PTO aerators, and water exchange permitted a channel catfish yield of 12,800 kg/ha (51). Production of over 10,000 kg/ha of catfish annually in ponds is an unrealistic expectation in commercial production of this species. Such high production requires considerable water exchange and frequent emergency aeration above the supplemental aeration applied on a daily basis. However, production of 10,000 to 20,000 kg/ha of various species of fish and of shrimp is achieved in commercial ponds in Israel and in Asia. Such high production is possible in small ponds (usually less than 1 ha) when aeration is applied at or above 5 kw/ha and there is considerable water exchange (10 to 30% pond volume per day) employed. Unfortunately, only a few studies of the use of aeration in high intensity aquaculture have been conducted, and these studies have not been sufficiently quantitative to permit generalization.

Channel catfish fingerlings were stocked in ponds at 1,200, 4,300, 8,600, 17,300, 26,000, and 34,600 per hectare, and maximum daily feeding rates of 0, 28, 56, 84, 112, 168, and 224 kg/ha, respectively, were established (32). Aeration was applied with vertical pump aerators at 6.1 kw/ha when DO concentration was expected to fall below 2 mg/l. Aerators were seldom operated in ponds with feeding rates of 0 to 56 kg/ha per day. Aeration was applied almost constantly at night in ponds with feeding rates of 112 kg/ha per day and above. Even though aeration prevented extremely low DO concentrations in all ponds, net fish production increased with feeding rate only up to 112 kg/ha per day. Feed conversion values were between 1.6 and 1.8 for daily feeding rates of 0 to 112 kg/ha. Feed conversion values were 2.5 and 16.5 for daily feeding rates of 168 and 224 kg/ha, respectively. Maximum net production of 6,000 kg/ha was achieved at a feeding rate of 112 kg/ha per day. Ammonia nitrogen accumulated in ponds, and high ammonia concentrations apparently limited production at high feeding rates. This experiment shows that production cannot be increased without limit. Some other water quality variable, probably ammonia, will impose limits on production even though there is adequate DO. Of course, water exchange can sometimes be used to improve water quality by reducing concentrations of ammonia and other toxic metabolites.

In an experiment conducted in 1986, channel catfish ponds were stocked at 10,000 fingerlings/ha and fed to a maximum daily rate of 53.2 kg/ha (42). Three ponds were aerated 6 hours per night from May 30 to October 12 at a rate equivalent to 6.25 kw/ha with vertical pump aerators that had an SAE of 1.34 kg O<sub>2</sub>/kw·hr. Three ponds served as un-aerated controls, but emergency aeration was occasionally applied in these ponds. An example of DO concentrations during the night in aerated and un-aerated ponds is illustrated in figure 27. Dissolved oxygen concentrations were always above 4 mg/l in aerated ponds, but DO concentrations below 2 mg/l often were recorded in un-aerated ponds. Harvest weight of fish averaged 4,813 kg/ha in aerated ponds and 3,659 kg/ha in un-aerated ponds. The same quantity of feed was applied to all ponds. Feed conversion values were 1.32 and 1.75 in aerated and un-aerated ponds, respectively. Production data were expanded to larger ponds for a budget analysis. Net returns to land, management, and equity capital were \$1,719/ha for aerated ponds and \$896/ha for un-aerated ponds. The experiment was repeated in 1987 with similar

results. Production in aerated ponds was 4,475 kg/ha as compared to 3,551 kg/ha in control ponds. Feed conversion values were 1.58 and 2.04 in aerated and unaerated ponds, respectively. These findings suggest that nightly aeration of ponds stocked and fed at moderate rates may be more profitable than aeration of heavily stocked and fed ponds.

Aerators for nightly aeration may be attached to an inexpensive timer and turned on and off at any desired time. Electric service panels for aerators which incorporate a motor starter, a timer, and an ammeter in a single weatherproof box may be purchased at a reasonable cost.

The results of the experiments summarized above suggest that in ponds where a large degree of water exchange is impractical, aeration can best be used with moderate feeding rates (50 to 60 kg/ha per day) to eliminate nighttime DO problems and increase production through enhancement of feed conversion efficiency. Extremely high feeding rates (60 to 100+ kg/ha per day) are necessary for production of 5,000 to 20,000 kg/ha. Such high levels of production necessitate water exchange or some type of water treatment to reduce concentrations of toxic metabolites. Aeration alone usually is not sufficient to permit the highest levels of production. Little is known about feed conversion values, and above a certain point, feed conversion probably begins to deteriorate even though net production continues to increase. Much additional research on relationships among feeding rate, water quality, aeration, water exchange, net production, and feed conversion efficiency is needed.

#### **Aerator Placement**

Water circulation tests show that aerators mix water throughout ponds, and paddle wheel aerators are especially efficient in circulating pond water. A recent study was conducted to ascertain the best position for a paddle wheel aerator in a rectangular pond. Sixty 1-l plastic bottles were filled with water so that they floated with only their caps above the water. These bottles were released at once in front of a 2.25-kw aerator in a 0.4-ha pond, and the paths of the bottles recorded. The best place to mount a paddle wheel aerator is at the middle of one of the long sides of the pond, figure 28. The aerator should direct water parallel to the short sides of the pond. The worst arrangement is to mount the aerator in one corner of the pond to direct water diagonally across the pond, figure 28. Although this arrangement was best for the particular pond, it would likely be necessary to use some other aerator placement pattern to achieve the best water circulation in ponds of other sizes or shapes. The technique using bottles that is given above could be used by shrimp farmers to decide where to place aerators in ponds.

Many people think that most aerators only mix surface water. This opinion is untrue. Tests with water current meters demonstrated that surface aerators propel water away from the aerator, and a return current of water is established at the pond bottom (Boyd and Moore, unpublished data).

## Operating Cost and Service Life

The initial prices of PTO aerators range from \$2,000 to \$4,000 U.S. per unit. Of course, a tractor must be available to power each unit. Operating cost will vary with tractor size and aerator efficiency. There are not sufficient data to estimate the amount of oxygen transferred by PTO aerators per liter of fuel, so the cost per kilogram of oxygen cannot be estimated.

Electric aerators vary tremendously in cost per unit. The usual range in cost is \$350 to \$1,200 U.S. per kilowatt. Small aerators are more expensive than large ones. For example, a 0.5-kw vertical pump aerator costs about \$500 (\$1,000/kw); a 2.25-kw paddle wheel aerator costs about \$1,500 (\$711/kw); a 7.5-kw paddle wheel aerator costs about \$2,800 (\$373/kw).

The only reliable way of determining the operating cost of a particular electric aerator is to attach a watt-hour meter to the aerator. The power use per hour can be determined, and the operating cost per hour estimated by multiplying the power use in kilowatt-hours by the cost of electricity per kilowatt-hour. An approximate method for estimating operating cost is to calculate power use from current and voltage. For a single phase motor, power may be approximated as:

$$P = \frac{(I)(V)}{1,000}$$

where P = power use (kw)  
I = current (amp)  
V = voltage (volt)

The equation for three-phase motors is:

$$P = \frac{(I)(V)(\sqrt{3})}{1,000}$$

Of course, the above equations are approximate because the power factor of the motor will be less than unity. For example, a three-phase, electric paddle aerator was operated at 225 volts and 27 amps. The actual power consumption as measured with a watt-hour meter was 9.44 kw. The power consumption estimated was 10.52 kw.

The cost of electricity is highly variable and depends upon many factors. The average cost of electricity in the United States is around \$0.075 per kilowatt-hour. Using this price of electricity, the hourly operating cost for the 7.5-kw electric paddle wheel aerator mentioned above would be \$0.708/hour (9.44 kw x \$0.075/kw-hr). In standard tests, the aerator had a standard oxygen transfer rate (SOTR) of 21.81 kg O<sub>2</sub>/hour. However, under pond conditions the actual oxygen transfer rate (AOTR) would seldom be more than 50% of the SOTR. Assuming an AOTR of 10.90 kg O<sub>2</sub>/hr, the cost of electricity per kilogram of oxygen would be

\$0.065. The DO concentration in ponds is constantly changing, so it is more reasonable to express the cost of electricity for aerators in terms of the cost per hour of operation.

The service life of aerators is highly variable and depends to a great extent upon care and maintenance. Lubrication of PTO aerators is essential. With proper lubrication, PTO aerators will last for many years.

Electric aerators must not be operated in a manner to overload the motor. Once the aerator is positioned in a pond, it should be verified that the current draw does not exceed the rated current for full load of the motor. Most electric motors have a service factor of 1.10 to 1.20, and can be operated at an overload of 110% or 120% for an extended period. However, this practice is not advisable, and it is best to run motors at a slight underload (95% full load is ideal). The current draw of a motor can change, so it should be checked periodically. Motor controllers are essential for aerators larger than 1 or 2 kw. These controllers have fuses (heaters) that protect the motor against an overload, but the overheating of the motor that occurs before the fuses break the controller circuit is harmful to the motor and reduces its service life. Motor controllers are built directly into small electric motors.

Care also must be taken to lubricate electric aerators and to maintain paint to resist corrosion. In saline water, corrosion is a major problem, and the use of corrosion resistant material is recommended.

Experience indicates that small aerators (\$2.25 kw) can be operated for about 2 years before major repairs are necessary. Larger aerators usually do not require major repairs for 4 or 5 years.

#### **WATER CIRCULATION**

There is a consensus among aquaculturists that water circulation in ponds is beneficial (28, 29, 30, 31, 38, 55). Water circulation prevents thermal and chemical stratification. This makes the entire pond volume habitable and eliminates oxygen depletion at the mud-water interface. High concentration of oxygen at the pond bottom is especially important in shrimp ponds, because shrimp spend a lot of time at the bottom.

Shrimp farmers often exchange water in ponds on a daily basis. Water exchange causes some circulation. There are many ideas about how to situate entrance gates and exit gates to achieve the best water circulation, but definitive answers are not available.

Aeration of pond water causes water circulation, and paddle wheel aerators are more efficient than other types in circulating pond water. There have been some studies of devices designed to circulate pond water (28, 38). Water circulation devices create surface turbulence and this effects a small degree of aeration. However, water circulators should not be considered aerators. The greatest influence of water circulators on oxygen concentration results because these devices blend surface

water with subsurface water. During daylight hours, surface waters in ponds often are supersaturated with DO, and water at greater depths may have low DO concentrations. By mixing pond water, a uniform DO profile can be established (31, 38, 55). Oxygen produced by phytoplankton is possibly conserved by water mixing, because the high degree of DO supersaturation normally found at pond surfaces during daylight is eliminated by mixing. Preliminary evidence suggests that the total DO content of a pond can be increased by mixing (30, 31, 38). An extensive research effort on water circulation in ponds would be worthwhile.

An air-lift pump designed by Parker (49) is illustrated in figure 29. The pump is constructed of a length of PVC pipe and a PVC elbow. Air from an air blower is released through a 90° hose adaptor into the PVC pipe. If desired, an air diffuser that releases smaller bubbles of air can be placed in the pipe. The rising air bubbles lift water through the pipe and discharge it at the pond surface. A pump holder is attached between the anchor post and the pump. This holder contains a flotation device and it permits the pump to pivot. Ballast must be provided at the bottom of the pump.

Parker (49) demonstrated that two 10-cm-diameter air-lift pumps with 122-cm vertical risers would pump the entire volume of water in a 0.2-ha pond in 3 days if 0.14 m<sup>3</sup>/min of air was injected into each vertical riser at a depth of 76 cm. Obviously, if a high degree of mixing is desired, a lot of air lift pumps would be required. For example, to achieve a pumping rate of one pond volume per day, a 1-ha pond with a depth of approximately 1 m would require thirty 10-cm-diameter air-lift pumps. Total air flow to the pumps would be 4.2 m<sup>3</sup>/min.

Researchers in Hawaii (38) designed, fabricated, and tested a device which they called a water circulator, figure 30. It consisted of a 61-cm-diameter fan (turbine impeller) attached to a shaft which was connected to a 0.19-kw electric gearmotor that provided an impeller speed of 60 rpm. The device was mounted on a small cart to facilitate mobility. Discharge was estimated at 5.7 m<sup>3</sup>/min.

The water circulator (38) was tested in 0.2-ha prawn ponds. In calm conditions without artificial circulation, the pond developed thermal stratification and DO concentrations in bottom water were often less than 5 mg/l DO during late afternoon. With artificial circulation, DO concentrations in bottom water sometimes exceeded 12 mg/l during late afternoon. Minimum daily DO concentrations in bottom water averaged 1.0 mg/l higher and maximum daily DO concentration in bottom water averaged 4.0 mg/l higher during artificial circulation. These findings suggested that artificial circulation increased the potential for prawn production.

#### **TOXIC METABOLITES**

As a result of metabolic activity by organisms in ponds, carbon dioxide, ammonia, and hydrogen sulfide sometimes may reach harmful concentrations.

## Carbon Dioxide

High concentrations of CO<sub>2</sub> can be tolerated by aquacultural species, although fish are known to avoid CO<sub>2</sub> concentrations as low as 5 mg/l. Most aquacultural species will survive in waters containing up to 60 mg/l CO<sub>2</sub>, provided DO concentrations are high. When DO concentrations are low, the presence of appreciable CO<sub>2</sub> hinders uptake of oxygen. Unfortunately, CO<sub>2</sub> concentrations normally are high when DO concentrations are low. This results because carbon dioxide is released in respiration and utilized in photosynthesis. Dissolved oxygen concentration declines when photosynthesis is not proceeding as rapidly as respiration; thus, CO<sub>2</sub> accumulates because it is not removed for use in photosynthesis.

Because of the necessity of light for photosynthesis, CO<sub>2</sub> concentrations increase at night and decrease during the day. High concentrations of CO<sub>2</sub> also occur in ponds during cloudy weather and following die-offs of phytoplankton or of filamentous algae.

It seldom is practical to remove CO<sub>2</sub> from pond waters. However, it sometimes is necessary to remove CO<sub>2</sub> from tanks or other containers in which shrimp or fish are reared or held. Removal may be effected by applying calcium hydroxide (CaOH<sub>2</sub>) or calcium oxide (CaO). For calcium hydroxide, apply 0.84 mg/l to remove 1 mg/l CO<sub>2</sub> (13). Less calcium oxide is needed; 0.64 mg/l of calcium oxide will remove 1 mg/l of CO<sub>2</sub>.

For example, water in a 25-m<sup>3</sup> tank contains 20 mg/l CO<sub>2</sub>. To remove 20 mg/l CO<sub>2</sub> with calcium oxide will require 20 mg/l x 0.64 = 12.8 mg/l calcium oxide. On a cubic meter basis, 12.8 mg/l calcium oxide will require 12.8 g/m<sup>3</sup> of the substance. Hence, 320 g (25 m<sup>3</sup> x 12.8 g/m<sup>3</sup>) of calcium oxide must be applied to the tank.

## Ammonia

Ammonia reaches pond water as a by-product of metabolism by animals and by decomposition of organic matter by bacteria (13). In water, ammonia nitrogen occurs in two forms, un-ionized ammonia (NH<sub>3</sub>) and ammonium ion (NH<sub>4</sub><sup>+</sup>), in a pH and temperature dependent equilibrium:

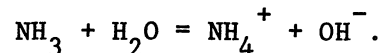

As pH rises, un-ionized ammonia increases relative to ammonium ion. Water temperature also causes an increase in the proportion of un-ionized ammonia, but the effect of temperature is less than that of pH. Analytical procedures for ammonia nitrogen measure both un-ionized and ionized ammonia. Percentages of un-ionized ammonia at different temperature and pH values are available in the literature (13, 36, 58).

The toxicity of ammonia nitrogen is attributed primarily to the un-ionized form. As ammonia concentrations in water increase, ammonia excretion by aquatic organisms diminishes, and levels of ammonia in blood and other tissue increases. The result is an elevation in blood pH and adverse effects on enzyme-catalyzed reactions and membrane stability. Ammonia increases oxygen consumption by tissues, damages

gills, and reduces the ability of blood to transport oxygen. Disease susceptibility also increases in organisms exposed to sublethal concentrations of ammonia (52, 60).

The tolerance of aquatic organisms to ammonia varies with species, physiological condition, and environmental factors. Lethal concentrations for short-term exposure (24 to 72 hours) are between 0.4 and 2.0 mg/l of un-ionized ammonia (13). Concentrations of total ammonia nitrogen necessary to give 0.4 mg/l un-ionized ammonia at 30°C and different pH values follow:

| pH   | <u>Concentration of total<br/>ammonia nitrogen to<br/>give 0.4 mg/l NH<sub>3</sub></u> |
|------|--|
|      | 7.0  |
| 7.5  | 15.62  |
| 8.0  | 5.32   |
| 8.5  | 1.93   |
| 9.0  | 0.89   |
| 9.5  | 0.56   |
| 10.0 | 0.45   |

Ponds seldom contain more than 2 or 3 mg/l of total ammonia nitrogen (13). Obviously, ammonia toxicity will be a greater problem at high pH. It is difficult to evaluate ammonia concentrations in ponds. Because of the daily cycle in pH, figure 1, un-ionized ammonia concentrations change continuously. Ammonia toxicity usually is expressed by reduced growth rate instead of mortality.

High ammonia concentrations are most common in ponds with high feeding rates. The only feasible means of reducing ammonia concentration is water exchange.

### Hydrogen Sulfide

Under anaerobic conditions, certain heterotrophic bacteria can use sulfate and other oxidized sulfur compounds as terminal electron acceptors in metabolism and excrete sulfide (13) as illustrated below:

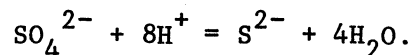

Sulfide is an ionization product of hydrogen sulfide and participates in the following equilibria:

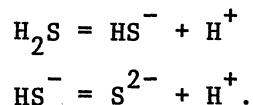

The pH regulates the distribution of total sulfide among its forms (H<sub>2</sub>S, HS<sup>-</sup>, and S<sup>2-</sup>). Un-ionized hydrogen sulfide is toxic to aquatic organisms; the ionic forms, however, have no appreciable toxicity. Analytical procedures measure total sulfide. Values given below show the percentages of un-ionized hydrogen sulfide at different pH values at 25°C:



| <u>pH</u> | <u>Hydrogen sulfide, pct.</u> |
|-----------|-------------------------------|
| 5.0       | 99.0                          |
| 5.5       | 97.0                          |
| 6.0       | 91.1                          |
| 6.5       | 76.4                          |
| 7.0       | 50.6                          |
| 7.5       | 24.4                          |
| 8.0       | 9.3                           |
| 8.5       | 3.1                           |
| 9.0       | 1.0                           |

The percentage of hydrogen sulfide decreases as the pH increases. A water containing 0.01 mg/l total sulfide would have an H<sub>2</sub>S concentration of 0.009 mg/l at pH 6 (0.01 x 0.911 = 0.009); the same total sulfide concentration at pH 8.5 would contain only 0.0003 mg/l H<sub>2</sub>S (0.01 x 0.031 = 0.0003).

Concentrations of 0.01 to 0.05 mg/l of H<sub>2</sub>S may be lethal to aquatic organisms (13, 57). Any detectable concentration of hydrogen sulfide is considered undesirable. The presence of hydrogen sulfide may be recognized without water analysis, for the "rotten-egg" smell of hydrogen sulfide is detectable at low concentration.

If water contains hydrogen sulfide, water exchange will reduce its concentration. Application of lime to raise the pH of the water will reduce the proportion of the total sulfide that is comprised of hydrogen sulfide.

#### **WATER SUPPLY**

Manufacturers of standard pumps provide data on power-head-discharge relationships for their pumps. These data are used to produce pump performance graphs which allow one to estimate pump discharges for different pumping heads. The pumping head is the vertical distance that water is lifted plus friction losses. Pump performance graphs also show the power required for each head-discharge possibility and pump efficiency for each head-discharge combination. Unfortunately, many shrimp farmers do not have performance data for their pumps. The best way of measuring pump discharge is to determine the length of time required to fill a basin of known volume. For example, suppose that a pond with an area of 1,000 m<sup>2</sup> and a depth of 1.3 m is filled by a pump in 4 hours. The total volume of the pond is 1,300 m<sup>3</sup>. Pump discharge is calculated as follows:

$$1,300 \text{ m}^3 \div (6 \text{ hr} \times 60 \text{ min/hr}) = 3.61 \text{ m}^3/\text{min}.$$

For smaller pumps, the time to fill a barrel or tank of known volume can be used to estimate discharge. Dimensions of the jet of water flowing from a pipe may be used to estimate pump discharge; a nomograph for calculating pipe discharge is provided, figure 31. This nomograph has English dimensions. Gallons per minute may be converted to liters per minute by multiplying gallons by 3.785.

Water budgets for shrimp ponds are relatively simple. Inputs are rain falling directly into ponds and water pumped into ponds. Runoff from levees will not contribute a significant amount of water. Normal monthly rainfall data can usually be obtained from governmental weather services. Pump discharge and time of pumping may be used to estimate the amount of water pumped into water supply canals or ponds.

Where water enters ponds through gates, the water usually flows over a rectangular weir-type structure. This structure may be used to measure inflow (44). The equation for the discharge of a rectangular weir is:

$$Q = 1.84(L_w - 0.2h)(h)^{3/2} \quad (60)$$

where  $Q$  = discharge in  $m^3/\text{min}$   
 $L_w$  = width of weir crest (the width of the structure over which water flows) in  $m$   
 $h$  = head (elevation difference between the weir crest and the water surface) in  $m$ .

To obtain an accurate measurement of discharge, the elevation of the water surface should be measured a distance equal to 4 times the head upstream from the weir crest. Therefore, a transit or level should be used to establish the elevation of the weir crest relative to a benchmark. Then, a staff gauge should be placed at an appropriate distance upstream from the weir. A staff gauge should be installed so that the exact reading of the staff gauge which corresponds to the elevation of the weir crest is known. This reading on the staff gauge corresponds to the water level that is exactly equal to the elevation of the weir crest. When the water level is higher than the weir crest, the staff gauge reading will afford an estimate of the depth (head) of water flowing over the weir.

To illustrate the calculation of water flow over a rectangular weir, suppose that a weir has a crest width of 1.00 m and the crest elevation corresponds to a staff gauge reading of 1.00 m. On a particular day, the staff gauge reads 0.71 m. Therefore, the head is  $1.00 - 0.71 = 0.29$  m. The discharge of the weir is:

$$Q = 1.84[1.00 - 0.2(0.29)](0.29)^{3/2} \quad (60)$$

$$Q = 16.2 \text{ m}^3/\text{min}.$$

If the head for a weir changes over time, it will be necessary to make several readings of the head during the water exchange period and average these readings.

Outputs of water are seepage, evaporation, and overflow during water exchange. Seepage is difficult to measure. Soils for shrimp ponds usually are heavy clays that do not seep appreciably. Seepage rates probably will not exceed 0.2 cm/day in most ponds. Evaporation usually is high year round in shrimp-farming regions. Pan evaporation data for Bangkok, Thailand, provided below show that evaporation rates are high in tropical areas.

| <u>Month</u> | <u>Pan evaporation, mm</u> | <u>Month</u> | <u>Pan evaporation, mm</u> |
|--------------|----------------------------|--------------|----------------------------|
| January      | 135                        | July         | 147                        |
| February     | 141                        | August       | 145                        |
| March        | 183                        | September    | 129                        |
| April        | 188                        | October      | 126                        |
| May          | 169                        | November     | 125                        |
| June         | 151                        | December     | 130                        |

Evaporation pans are commonly used by meteorologists to estimate potential evaporation. Pond evaporation may be calculated by multiplying 0.8 by pan evaporation (15). Discharge from ponds can be measured by weirs, but it is more convenient to estimate discharge by difference when the volumes of all other variables are known (14).

### WATER EXCHANGE

Water exchange serves several purposes: it flushes nutrients and phytoplankton from ponds to prevent excessive phytoplankton blooms; it removes toxic metabolic wastes such as ammonia; it dilutes pond water, so that salinity does not become excessive during the dry season.

Water pumped into ponds should be applied at the pond surface. Water should be drained from near the pond bottom and at the opposite side from which it is introduced. The most beneficial means of exchanging water in a pond is to first drain out the volume to be exchanged and then pump in an equal volume of replacement water. However, many farmers just pump water into a pond and allow the pond to overflow.

Water exchange rates used by farmers in various countries range from 5 to 30% per day. The water exchange rate in shrimp farming probably averages about 10% per day, which appears to be more than necessary for ponds with stocking densities less than 8 or 10 shrimp per square meter. If water quality in ponds is good, there is no reason to exchange water. Additionally, water quality in supply canals or reservoirs sometimes may be of lower quality than waters in ponds.

The water exchange rate in a pond may be estimated as follows, if the pond is full of water:

$$ER = \frac{[(PR \times T) + P] - (S + E)}{V} \times 100$$

where ER = exchange rate, % pond volume/day  
 PR = pumping rate, m<sup>3</sup>/hr  
 T = time of pumping per day, hr  
 P = precipitation, m<sup>3</sup>/day  
 S = seepage, m<sup>3</sup>/day  
 E = evaporation, m<sup>3</sup>/day  
 V = pond volume, m<sup>3</sup>

Suppose that a pond has an area of 1 ha and an average depth of 80 cm. Water will be pumped into the pond at a rate of 5 m<sup>3</sup>/min for 5 hours per day. The evaporation rate is 0.5 cm/day, and seepage is 0.2 cm/day. Calculations will be made assuming that there is no rain.

- (i) Pond volume = 10,000 m<sup>2</sup> x 0.8 m = 8,000 m<sup>3</sup>
- (ii) Pump rate = 5 m<sup>3</sup>/min x 60 min/hr = 300 m<sup>3</sup>/hr
- (iii) Evaporation = 10,000 m<sup>2</sup> x 0.005 m/day = 50 m<sup>3</sup>/day
- (iv) Seepage = 10,000 m<sup>2</sup> x 0.002 m/day = 20 m<sup>3</sup>/day

$$ER = \frac{(300 \text{ m}^3/\text{hr} \times 5 \text{ hr/day}) - (50 \text{ m}^3/\text{day} + 20 \text{ m}^3/\text{day})}{8,000 \text{ m}^3} \times 100 = 17.9\%$$

The influence of evaporation on salinity may be quite drastic. To illustrate, suppose that the water level in a pond is maintained at a constant depth by pumping in just enough water to replace evaporation and seepage losses. Seepage will not affect salinity, because salts leave the pond with the seeping water. However, salts are not lost when water evaporates. If the evaporation rate in an 80-cm-deep pond is 0.5 cm/day, water lost to evaporation is equal to 0.62% of pond volume per day [(0.5 ÷ 80) x 100 = 0.62%]. Thus, salinity will increase by 0.62% per day. Suppose that salinity was 27 ppt at the beginning of a month. By the end of the month, salinity would have increased to 32.02 ppt [27 ppt + 30(27 x 0.0062) = 32.02 ppt]. Even with water exchange, salinity will increase, but at a lesser rate; it will be in direct proportion to the water exchange rate.

In estimations of water exchange, it is necessary to know pond volume. One also must know pond volumes to calculate chemical treatments of ponds, e.g., application of chemicals to combat diseases. Pond volume is estimated as area multiplied by average depth. For rectangular or square ponds, one only need measure the length and width and multiply the two dimensions to obtain area. For irregular shaped ponds, surveying techniques must be used to obtain areas. Average depth may be obtained by making depth soundings at a number of places in a pond with the aid of a calibrated rod. Depths are then averaged. The best way of obtaining soundings is to travel across the pond in an S-shaped pattern and make soundings at frequent intervals.

Suppose that a pond is 100 m long and 40 m wide; results of soundings, in meters of depth, are: 0.25, 0.75, 0.85, 0.95, 0.78, 0.91, 0.82, 0.77, 0.91, 0.91, 1.05, 1.10, 1.01, 0.96, 0.89, 0.75, 0.68, 0.70, 0.72, 0.65, 0.66, 0.58, 0.48, and 0.16. Calculations of pond volume follow:

- (i) Area = 100 m x 40 m = 4,000 m<sup>2</sup>
- (ii) Average depth =  $\frac{0.25 + 0.75 + \dots + 0.16 \text{ m}}{24} = \frac{18.29}{24} = 0.76 \text{ m}$
- (iii) Pond volume = 4,000 m<sup>2</sup> x 0.76 m = 3,040 m<sup>3</sup>.

### POND BOTTOMS

Pond bottom soils react with water and influence water quality. Furthermore, shrimp spend much of their time on pond bottoms, and pond bottom conditions are more critical for shrimp than for most other aquacultural species.

Waters in coastal areas often are heavily laden with silt, and sediment ponds should be employed to remove silt. However, if sediment ponds are not used, silt should be removed when ponds are drained. Pond bottoms also should be dried. This insures that all contaminating organisms are killed and that soil is aerated. For maximum benefit, pond bottoms should be worked with a plow. The top 10 to 15 cm of soil should be tilled. If pond soils are acidic, application of about 500 kg/ha of calcium oxide over dry pond bottoms at the time tilling is done would be beneficial.

Bottoms of ponds should be smoothed and sloped to facilitate draining. In some places, ponds have been constructed with a central pond area that is more shallow than the pond bottom just inside the levees. This practice should be avoided, because water will not flow well across the shallow area. It will flow across the deeper areas. If water forms puddles in bottoms after draining, puddles should be treated with tea seed cake, rotenone, or chlorine to kill wild organisms.

Pond managers often wonder about black mud in pond bottoms. The black color of mud usually is caused by an accumulation of ferrous iron which results when the mud is depleted of oxygen. When the mud is oxidized (contains oxygen), the ferrous iron changes to ferric iron and the mud will no longer be black. A brown crust at the mud-water interface suggests that there is oxygen at the mud surface. However, if this crust is disturbed, the mud beneath usually will be black.

Some readers will have heard of the redox potential of pond water and mud. In simplest terms, the redox or oxidation-reduction potential is a measure of the proportion of oxidized to reduced substances in a solution or mixture. In practice, the redox potential is measured with respect to a hydrogen electrode and is called the  $E_h$ . If electrons flow from the solution to the electrode, reducing conditions are said to exist in the solution and the electron flow in volts is assigned a negative sign. Oxidizing conditions are said to exist in the solution when electrons flow from the electrode to the solution and the voltage is given a positive sign. The opposite convention regarding signs is used by some workers.

The redox potential of oxygenated water is the result of the oxygen potential,

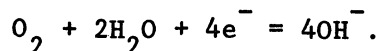

At oxygen saturation and pH 7, the redox potential of water ( $E_h$ ) at 25°C should be 0.80 volt. However, because of phenomena associated with the measurement of the oxygen potential, the  $E_h$  of oxygenated natural waters ranges from 0.45 to 0.52 volt. A change in  $E_h$  of 0.059 volt occurs per unit change in pH. This change is negative for pH values below 7 and positive for values above 7. Values for  $E_h$  are often corrected to pH 7. Temperature has little influence on  $E_h$ , as long as DO is present, the redox potential remains at about 0.5 volt, but once DO is depleted  $E_h$  drops rapidly.

In a shrimp pond, the water above the mud usually contains dissolved oxygen and the water has an  $E_h$  near 0.5 volt. Water cannot exchange freely between the pond and the pore spaces in the mud, so microbial activity depletes DO concentrations in mud. Thus, the  $E_h$  drops rapidly with depth beneath the mud surface. Reducing conditions (anaerobic conditions) usually occur at depths greater than 1 or 2 cm into mud. The  $E_h$  tends to decline with depth in the mud. Values of  $E_h$  associated with the appearance of various reduced substances follow:  $NO_2^-$ , 0.4 volt;  $Mn^{2+}$  and  $Fe^{2+}$ , 0.2 volt;  $H_2S$ , 0.1 volt. The appearance of ferrous iron ( $Fe^{2+}$ ) and manganous manganese ( $Mn^{2+}$ ) coincide closely with the point where DO just becomes depleted. Values for  $E_h$  as low as -0.1 volt have been recorded in mud.

In shrimp ponds, the development of reducing conditions at the surface of the pond mud is a highly undesirable event. Water circulation in ponds caused by water exchange, wind, or aeration tends to move water across the mud surface and prevent the development of reduced conditions. As mentioned before, reduced mud has a deep black color.

### HEAVY METALS

Fairly high concentrations of heavy metals have been reported in estuarine waters in many nations. Thus, there is interest in the toxicity of heavy metals to shrimp and other aquacultural species. The toxicity of heavy metals to a variety of species of freshwater and marine animals, mostly fish, were obtained from various publications and summarized below:

| <u>Metal</u> | <u>Range of 96-hr<sup>1</sup><br/>LC-50 (µg/l)</u> | <u>Safe level recommended<br/>by U.S. Environmental<br/>Protection Agency (µg/l)</u> |
|--------------|--|--|
| Cadmium      | 80-420   | 10   |
| Chromium     | 2,000-20,000                                       | 100  |
| Copper       | 300-1,000  | 25   |
| Lead         | 1,000-40,000                                       | 100  |
| Mercury      | 10-40  | 0.10   |
| Zinc         | 1,000-10,000                                       | 100  |

<sup>1</sup>The 96-hr LC-50 is the concentration of a substance which will kill 50% of the organisms in a laboratory toxicity test within a 96-hr exposure time.

The safe levels recommended by the U.S. Environmental Protection Agency are conservative estimates, which are 10 to 100 times lower than the lowest concentrations which have been reported to harm organisms in laboratory toxicity tests.

The procedure for heavy metal analysis (atomic absorption spectrophotometry) measures the total concentration of a particular metal. Waters for shrimp ponds contain suspended clay particles and organic matter. Heavy metals are adsorbed onto clay particles and chelated by organic matter. Some of the heavy metals also form complexes with oxides, hydroxides, and carbonates in water. The toxicity of heavy metals is related primarily to the dissolved, ionic form of the metal, e.g.,  $\text{Cu}^{2+}$  or  $\text{Zn}^{2+}$ , rather than to adsorbed, chelated, or complexed forms. A small percentage of the heavy metals in most waters are in ionic form, so toxicity of heavy metals should not be a problem in brackishwater ponds.

### PESTICIDES

A number of pesticides are used on agricultural crops in tropical nations, and pesticides enter rivers in runoff. Chlorinated hydrocarbon insecticides have the greatest potential for harming shrimp and fish. Toxicities of some selected insecticides to a wide array of freshwater and marine animals are summarized below:

| <u>Metal</u>    | <u>Range of 96-hr<br/>LC-50 (<math>\mu\text{g}/\text{l}</math>)</u> | <u>Safe level recommended<br/>by U.S. Environmental<br/>Protection Agency (<math>\mu\text{g}/\text{l}</math>)</u> |
|-----------------|---|---|
| Aldrin/Dieldrin | 0.20-16   | 0.003   |
| BHC             | 0.17-240  | 4   |
| Chlordane       | 5-3,000   | 0.01  |
| DDT             | 0.24-2  | 0.001   |
| Endrin          | 0.13-12   | 0.004   |
| Heptachlor      | 0.10-230  | 0.001   |
| Toxaphene       | 1-6   | 0.005   |

Again, the recommended safe level is well below the lowest concentration of an insecticide reported to harm aquatic organisms in laboratory toxicity tests.

Apparently, the use of pesticides with long residual lives is declining in most nations, and many pesticides that are used today degrade to non-toxic forms within a few days. However, pesticides are potentially harmful until they are degraded. The use of pesticides in shrimp farming areas should be discouraged. Pesticides sprayed onto fields may drift over considerable areas and reach ponds or canals. Key factors for protecting ponds from pesticides are as follow: put shrimp farm a considerable distance from pesticide-treated fields; plant trees or other high-growing vegetative cover between ponds and pesticide-treated fields to intercept airborne drift of pesticides; construct topographic barriers (ditches or terraces) to prevent runoff from fields from entering ponds; finally, use proper methods of pesticide application to fields. The disposal of pesticides and

pesticide containers should be done in such a way that pesticides do not contaminate waterways.

### MEASUREMENT OF WATER QUALITY

For research purposes, standard laboratory procedures are available for making water analyses. However, such procedures are not practical for use by shrimp farmers. Hach water analysis kits provide relatively accurate measurements of water quality in waters of salinities of 0 to 30 ppt (20). The Hach Fish Farmer's Water Quality Test Kits Models FF-2 and FF-1A (Hach Company, Loveland, Colorado) can provide reliable estimates of dissolved oxygen, carbon dioxide, pH, total alkalinity, total hardness, chloride, total ammonia nitrogen, and nitrite nitrogen for use in shrimp pond management. However, when purchasing these kits, one should indicate that the kits will be used in salt water so that the titrating agents provided in the kit will be of sufficient strength. Suitable water analysis kits are manufactured by other companies; Hach kits were mentioned only because a study of their performance has been published.

Salinity may be measured with a hand-held refractometer (usually called a salinometer). The salinity of water affects the refractive index, and the salinometer translates this effect into a reading of salinity in parts per thousand. Salinometers are expensive and delicate; they should be handled carefully. However, as mentioned earlier, salinometers are not accurate when salinity is low. For salinities below 4 or 5 ppt, chloride should be measured by titration using a water analysis kit and the following equation from Boyd and Lichtkippler (21) used to estimate salinity:

$$\text{Salinity (ppt)} = \frac{30 + (1.805 \times Cl)}{1,000}$$

where Cl = chloride concentration, mg/l.

Although dissolved oxygen can be measured with water analysis kits, it is tedious and costly to make dissolved oxygen measurements with water analysis kits when many ponds must be checked each day. Therefore, the use of dissolved oxygen meters is suggested. When using oxygen meters, always check the membrane for tears and to ascertain that an air bubble is not beneath the membrane. The accuracy of oxygen meters should be verified often. To do this, saturate the water in a container by pouring the water back and forth between two containers 40 or 50 times. Check the temperature and salinity of the water and determine the dissolved oxygen concentration at saturation from table 7. Read the dissolved oxygen in the container with the oxygen meter. The meter should give a reading of  $\pm 0.5$  mg/l of the expected saturation concentration.

The amount of suspended matter in water that will settle out quickly is termed settleable solids. The settleable solids are determined with an Imhoff cone, figure 32. The cone holds 1 l of water and the lower end of the cone is graduated so that the volume of



sediment may be read directly. To measure settleable solids, the water sample is thoroughly mixed and 1 l of sample is poured immediately into the Imhoff cone. The cone is set aside, left to stand for 60 minutes, and then the volume of sediment in milliliters per liter is read directly.

#### ACKNOWLEDGMENTS

The preparation of this manual was supported by the Asian Development Bank, Manila, Philippines, and by the U.S. Agency for International Development through AID Cooperative Agreement (DAN-4180- A-00-8008-00), AID Program Support Grant (DAN-5058-G-55-6073-00), and AID (CRSP) (DAN-4023-G-SS-706600). C. R. "Corny" Mock kindly read the manuscript and made several helpful suggestions.



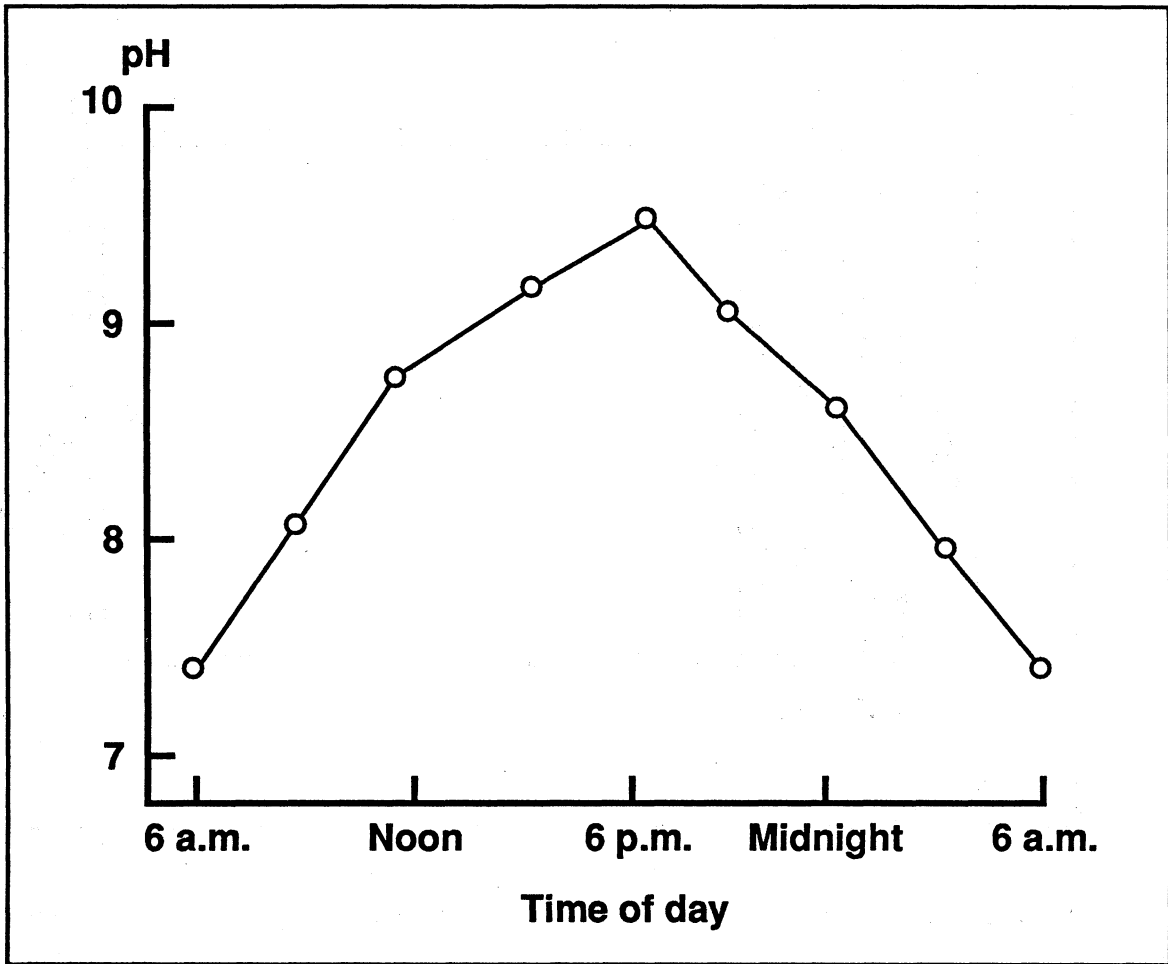

FIG. 1. Daily fluctuation in pH in a fish culture pond.

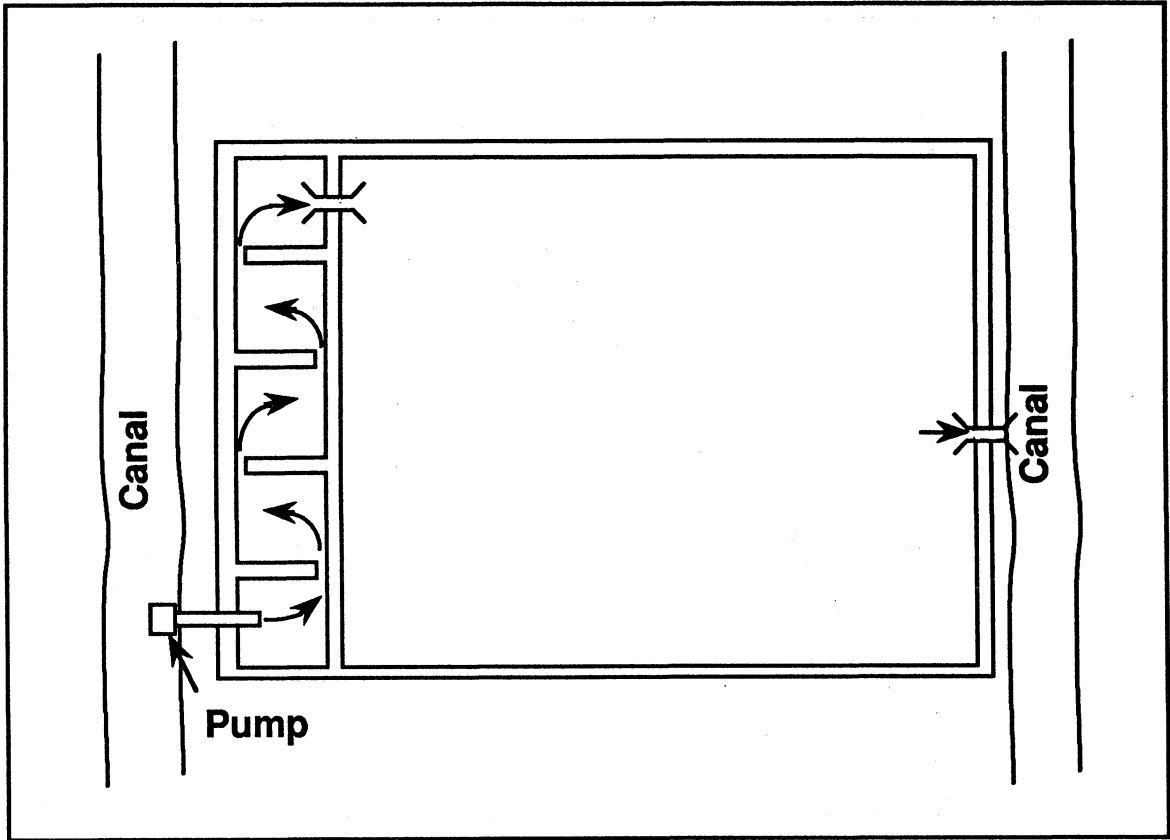

FIG. 2. Sediment pond installed in an existing shrimp culture pond.

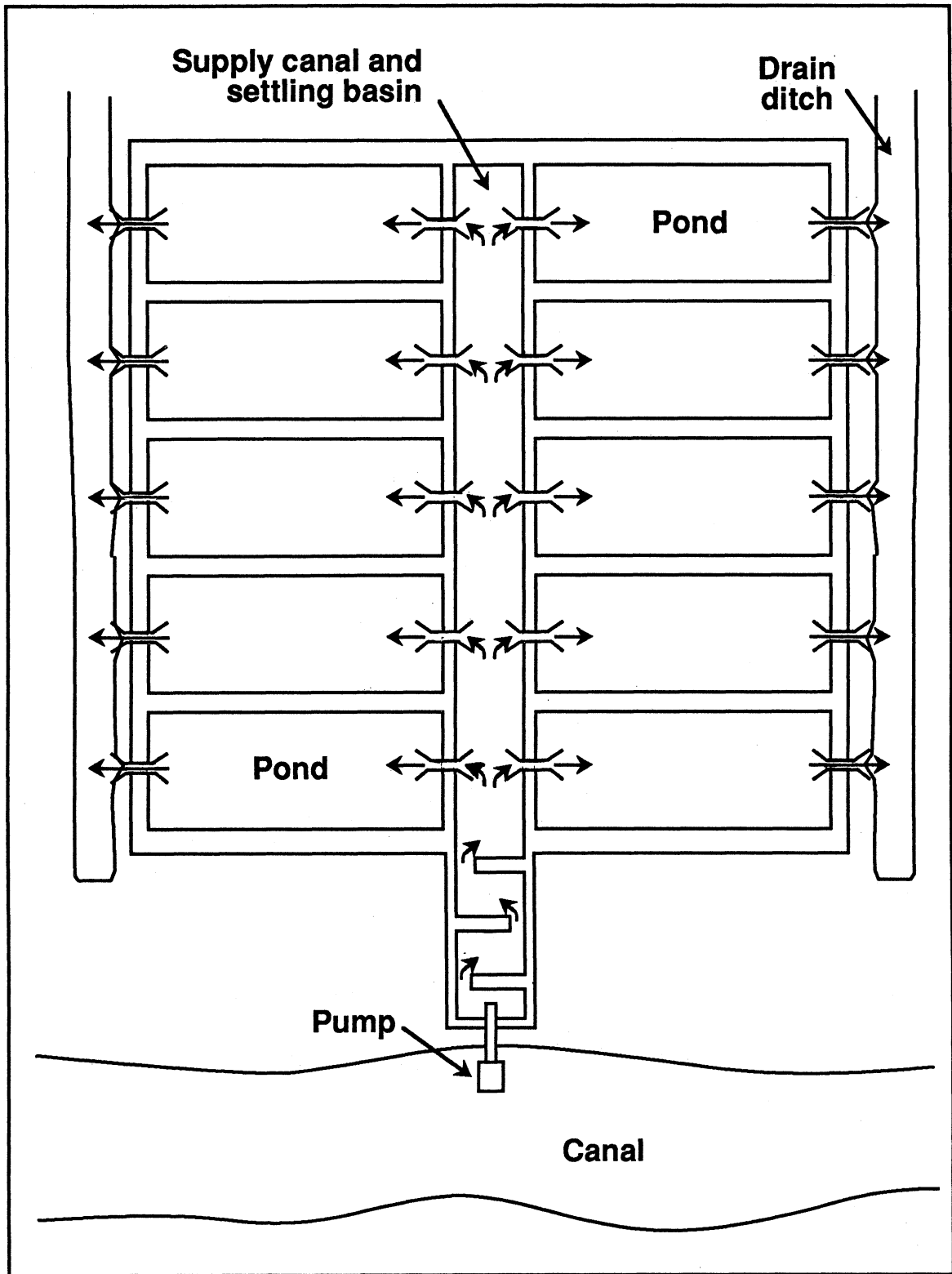

FIG. 3. Use of water supply canal as a sediment pond.

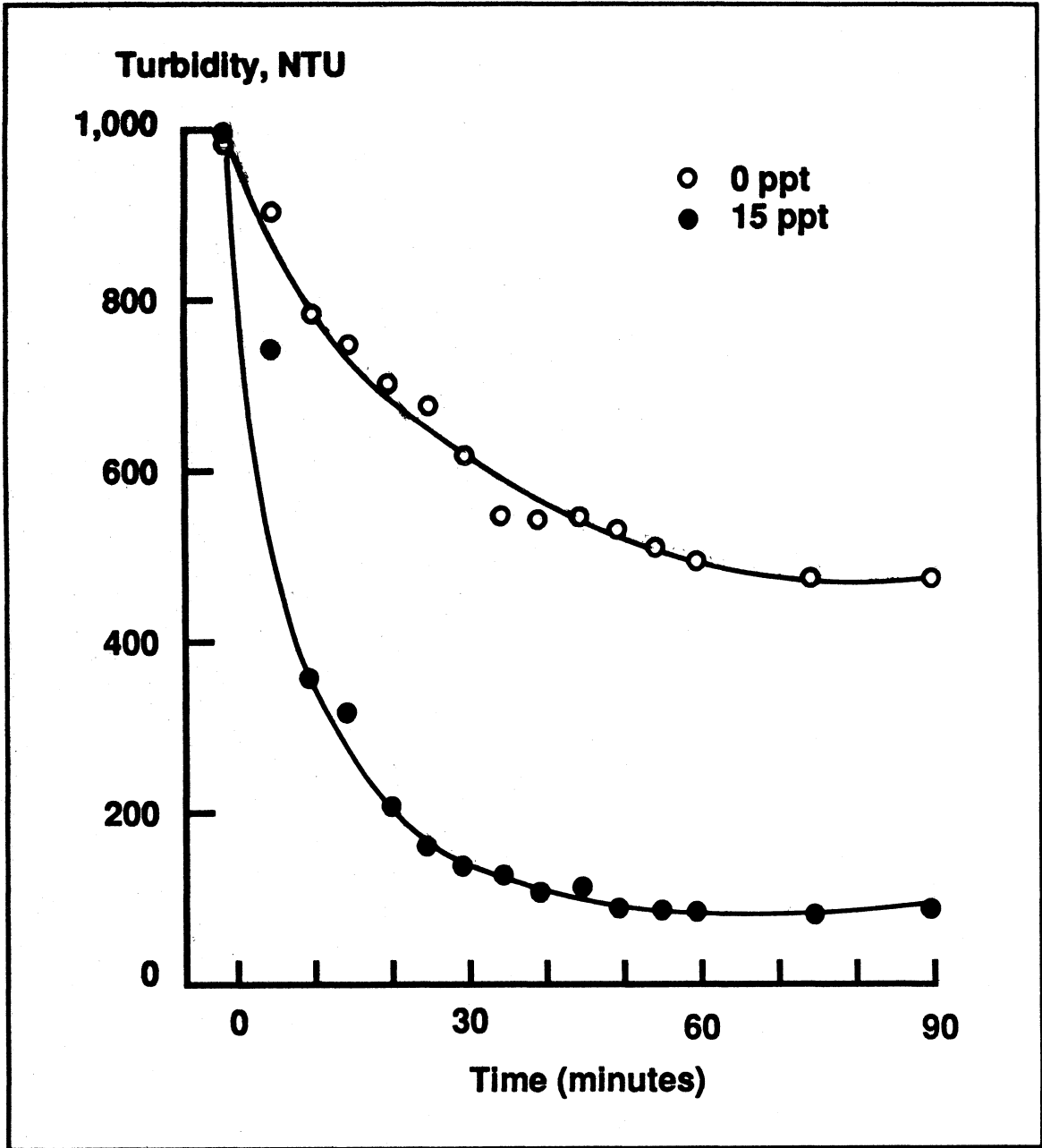

FIG. 4. Sedimentation rates for two soils in waters of 0 ppt and 15 ppt salinity.

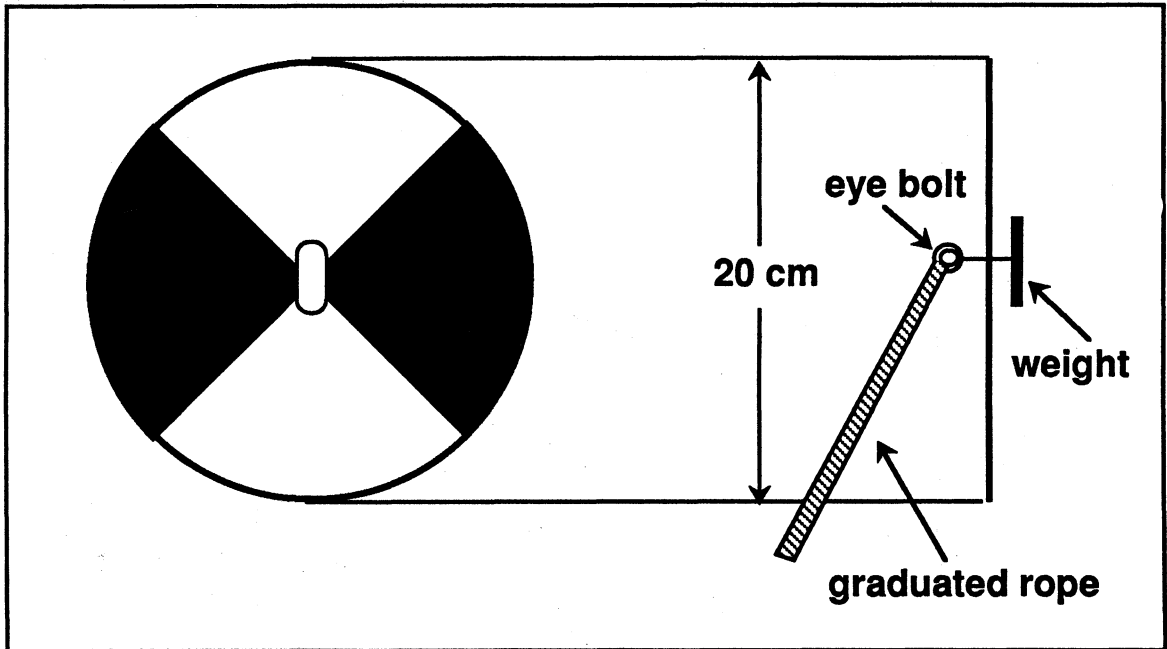

FIG. 5. A Secchi disk.

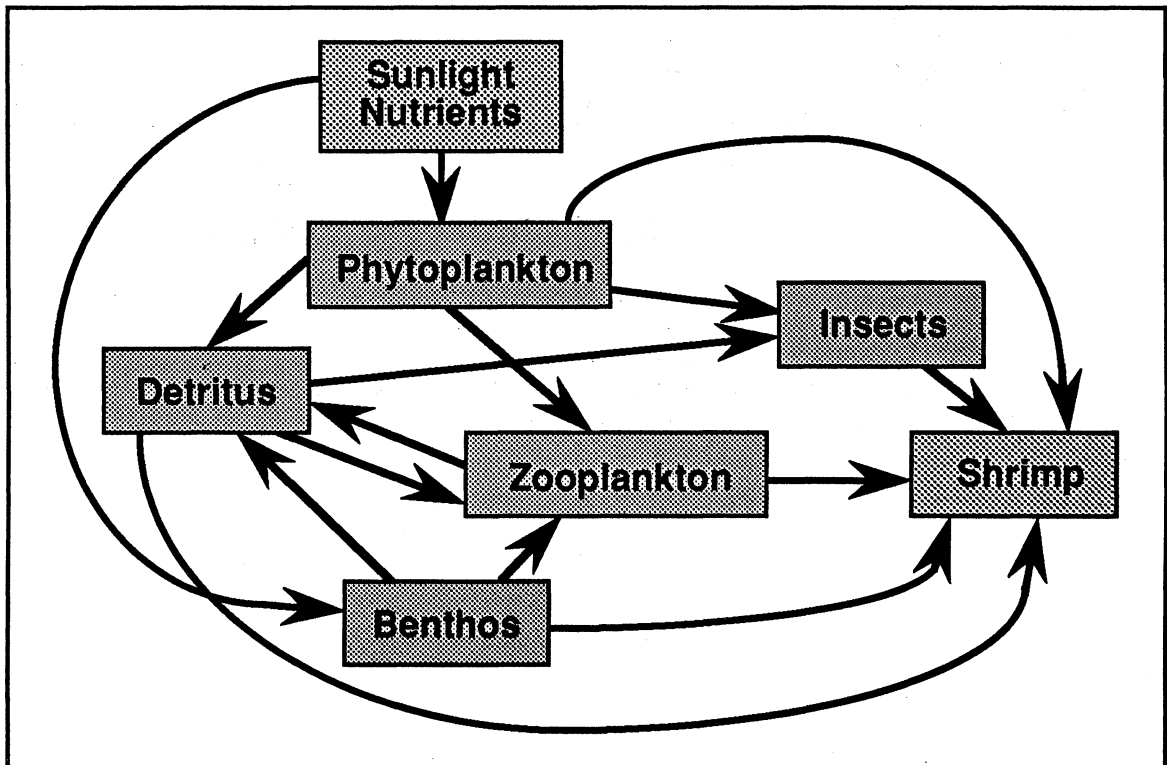

FIG. 6. The food web in a shrimp pond. Feed may be applied to supplement natural food.

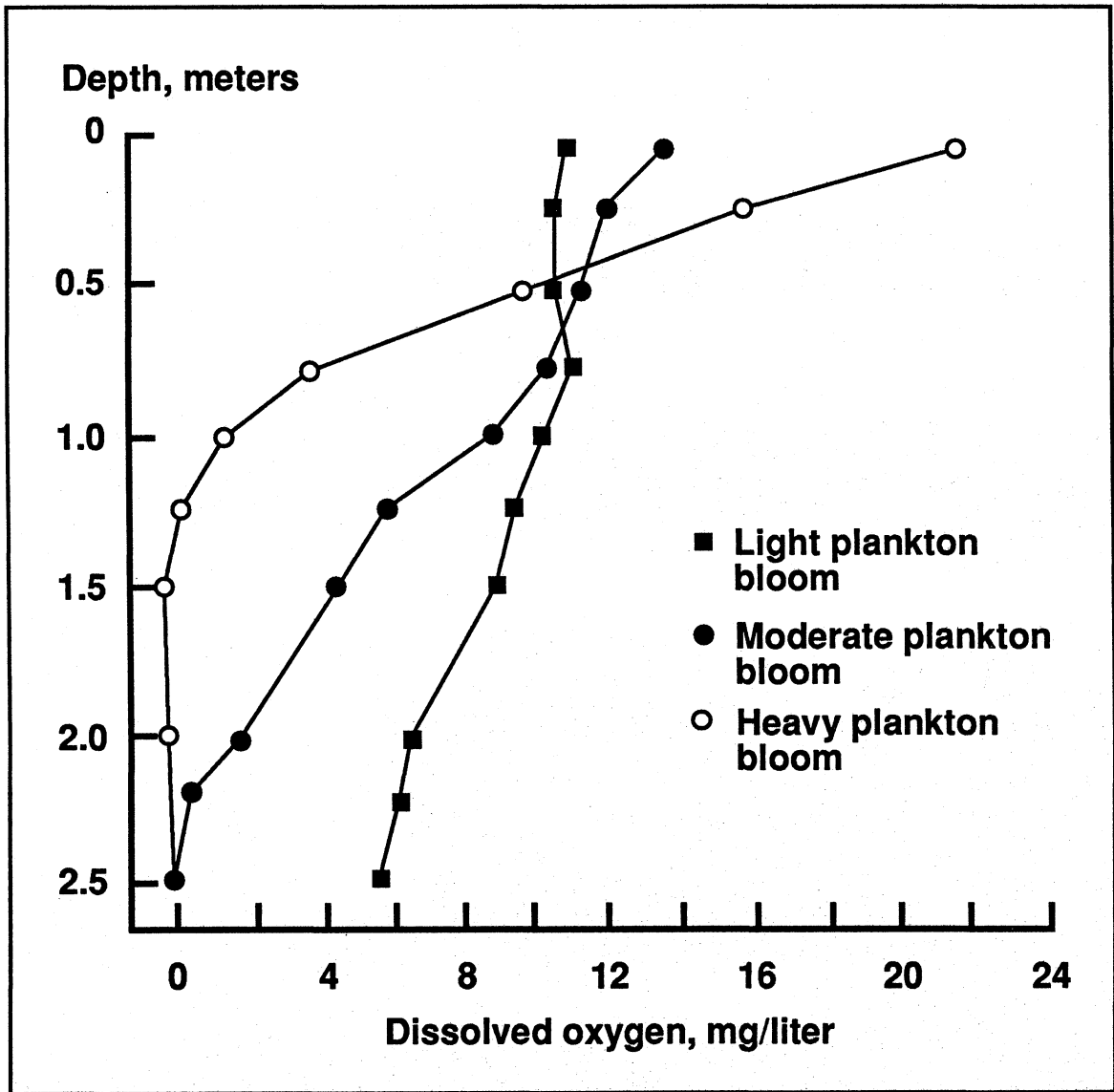

FIG. 7. Influence of depth on dissolved oxygen concentrations in ponds with different amounts of plankton.



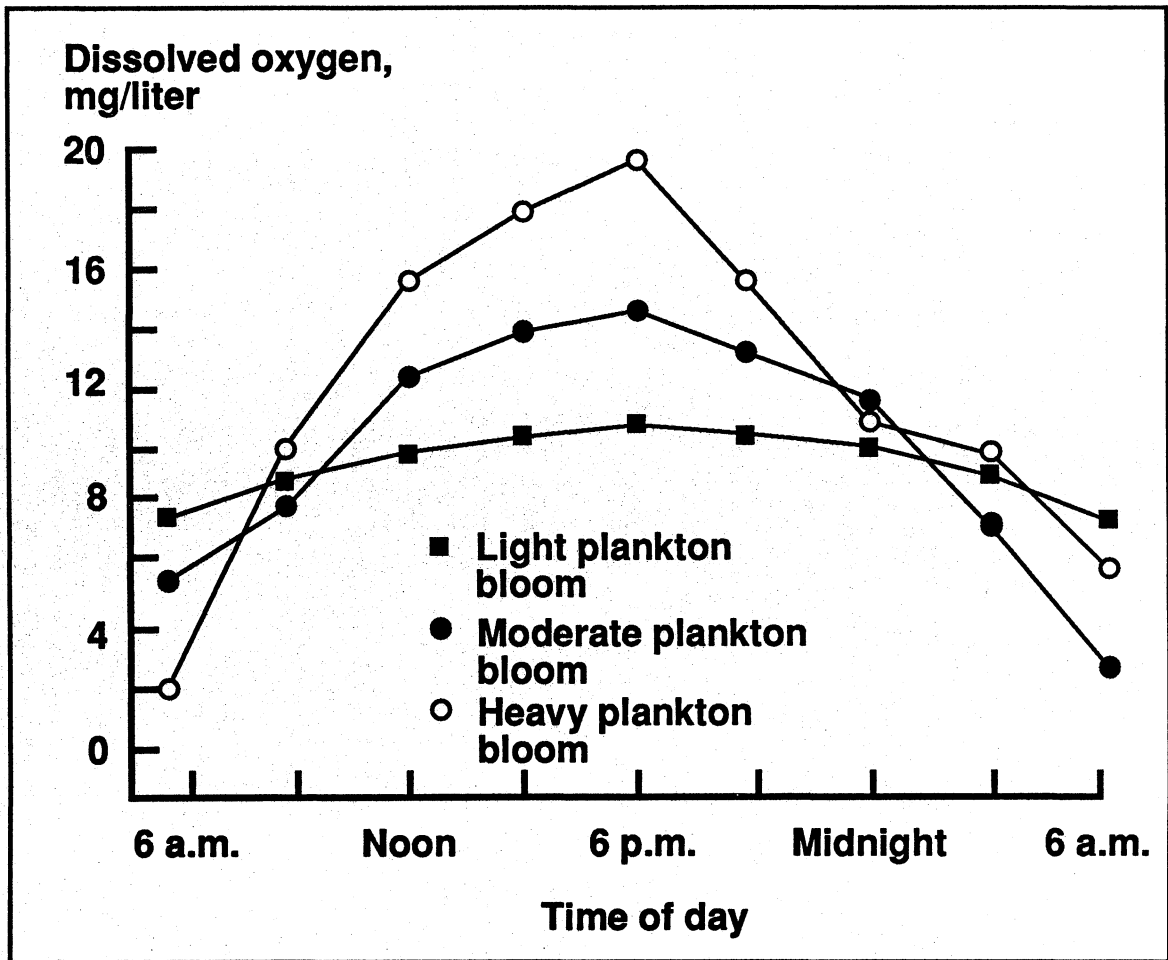

FIG. 8. Effect of time of day and plankton density on concentrations of dissolved oxygen in surface water.

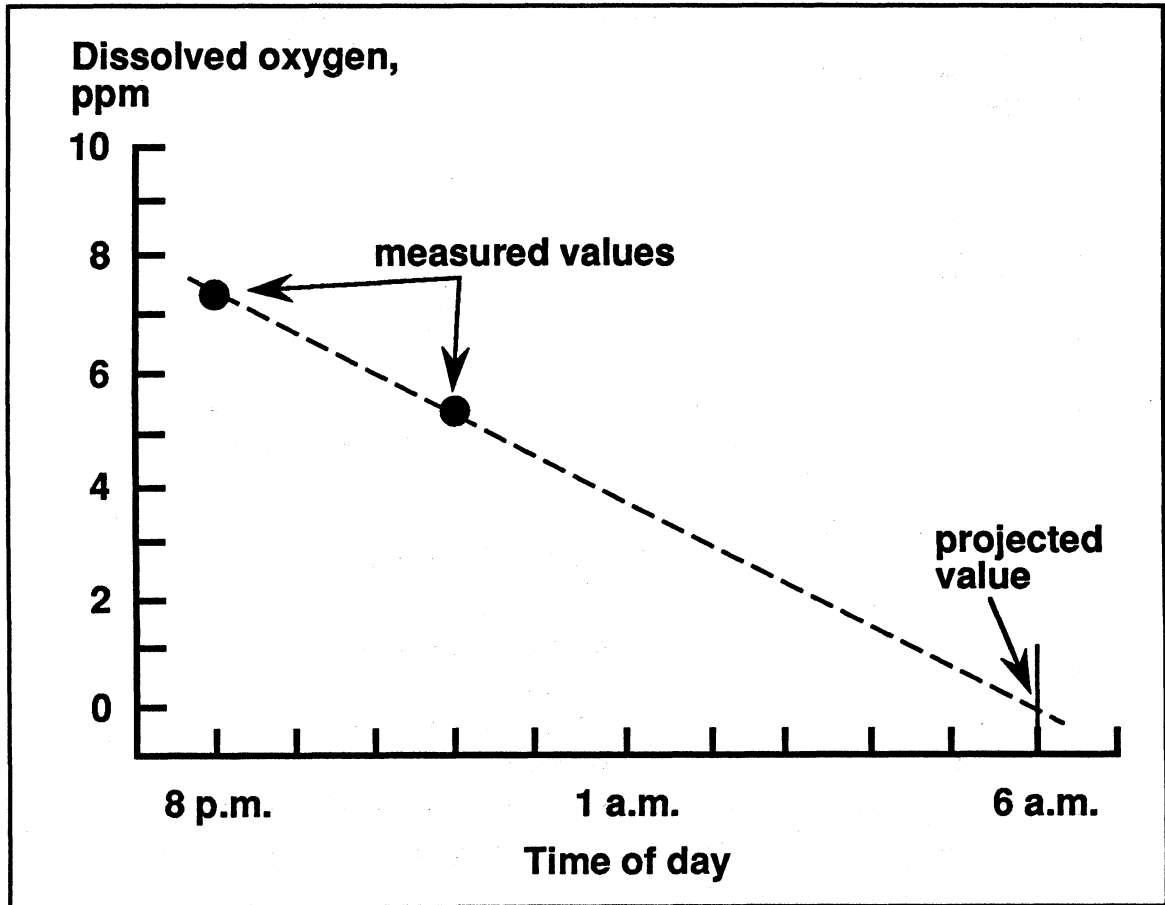

FIG. 9. Graphical representation of a procedure for predicting the nighttime decline in dissolved oxygen in a pond.

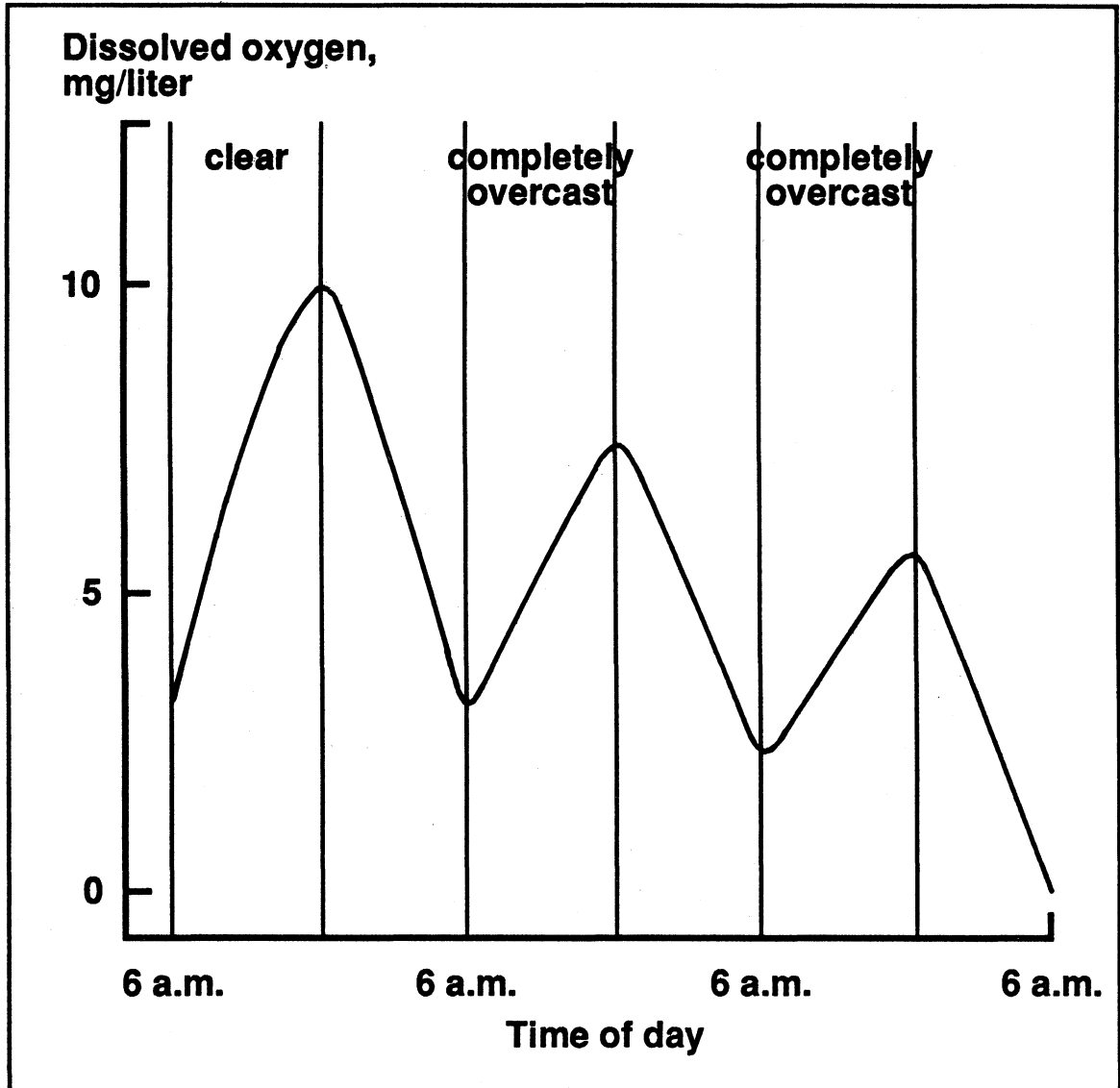

FIG. 10. Effect of cloudy weather on dissolved oxygen concentrations in a pond.

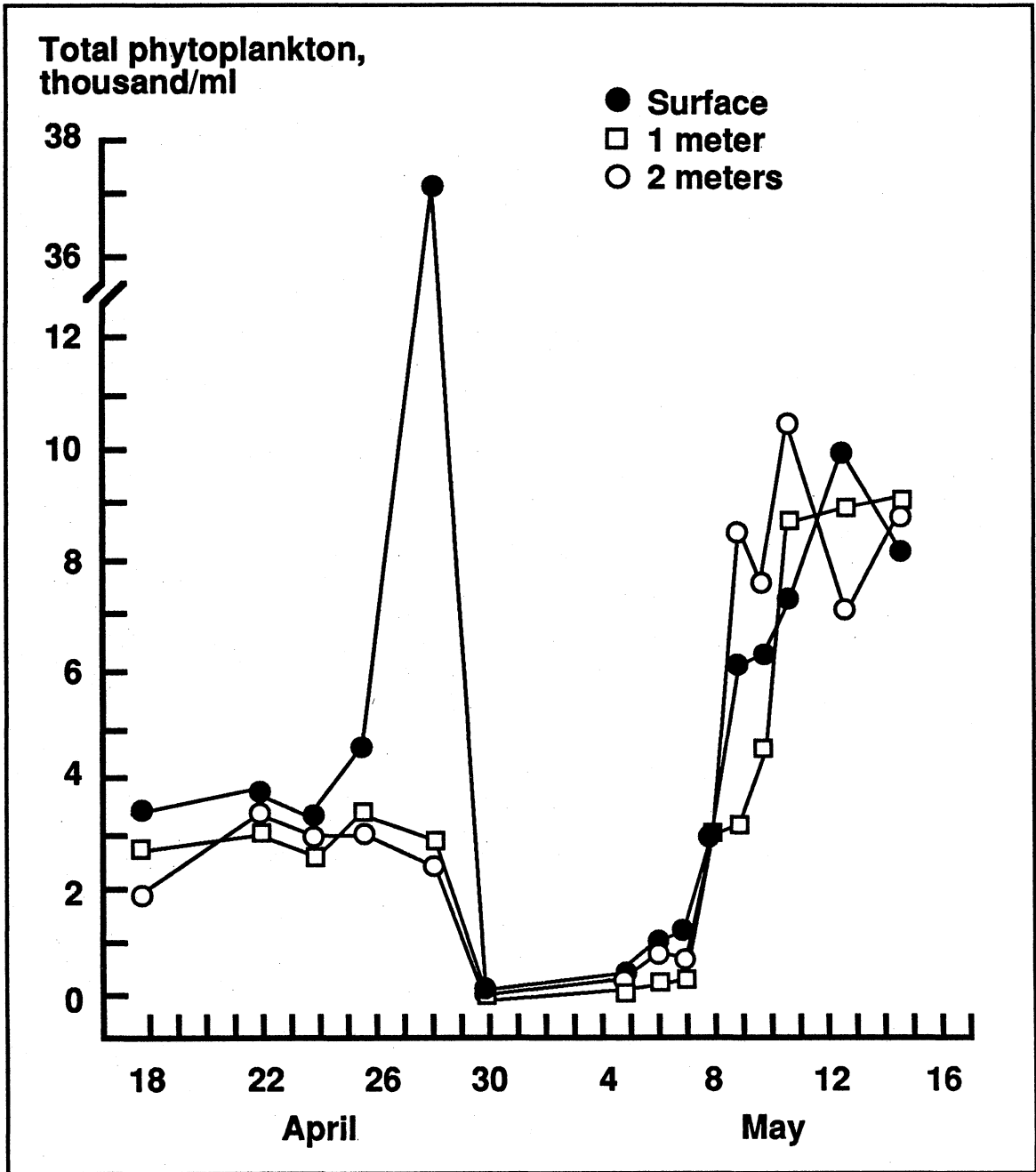

FIG. 11. Changes in phytoplankton abundance before, during, and after a massive phytoplankton die-off in a pond.

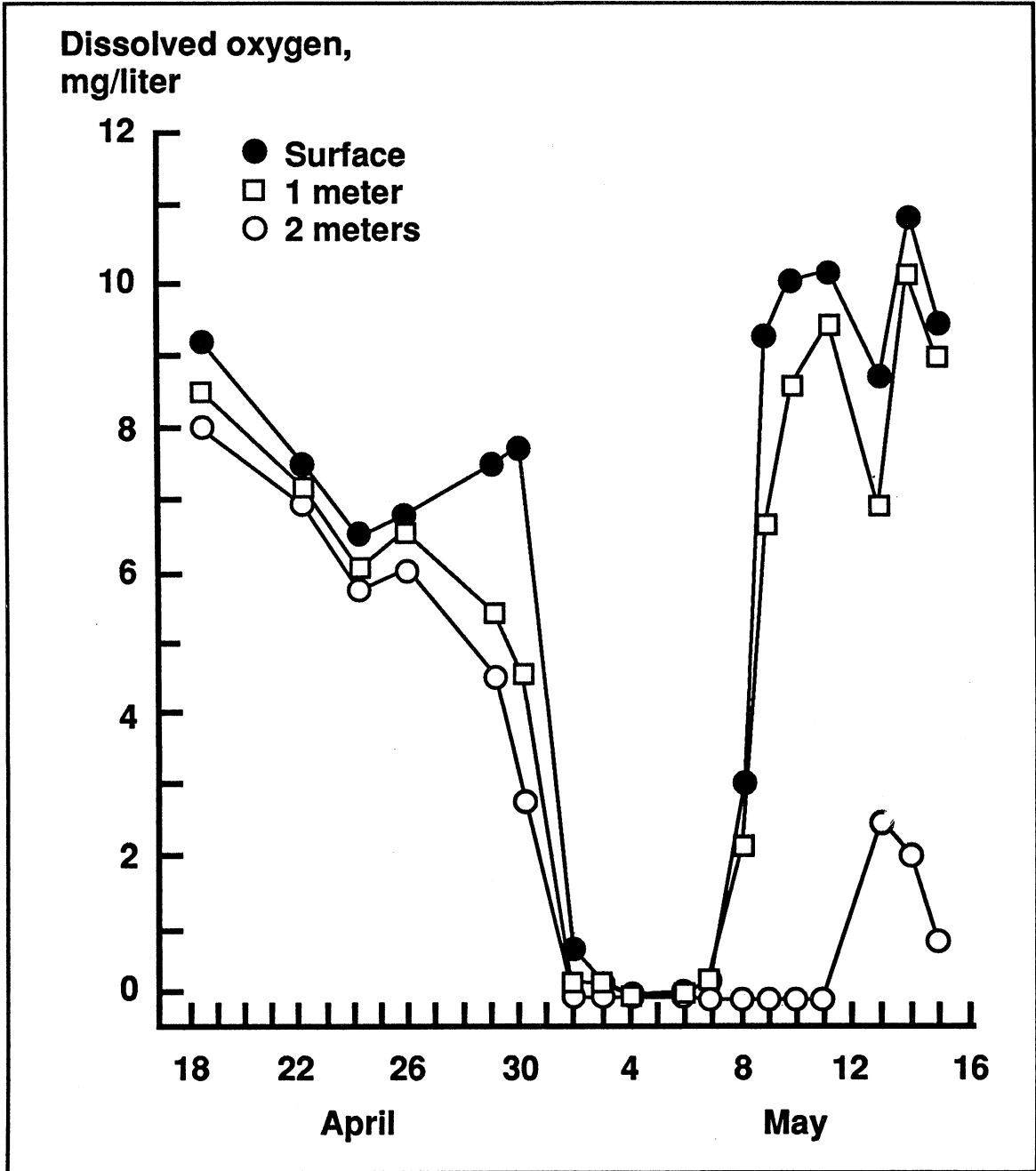

FIG. 12. Dissolved oxygen concentrations before, during, and after a massive phytoplankton die-off in a pond.

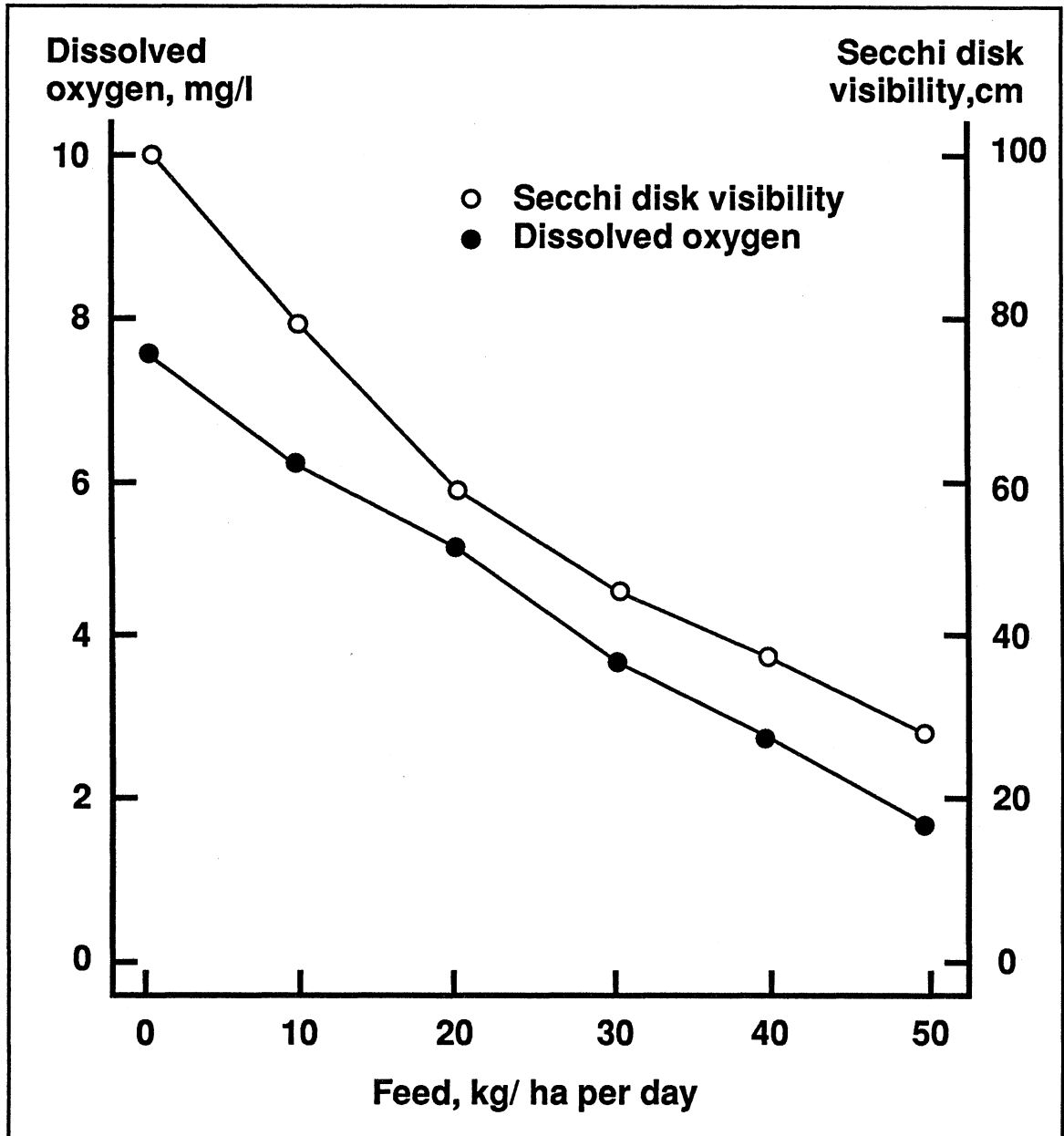

FIG. 13. Effect of feeding rate on dissolved oxygen concentrations at dawn and Secchi disk visibilities in ponds.

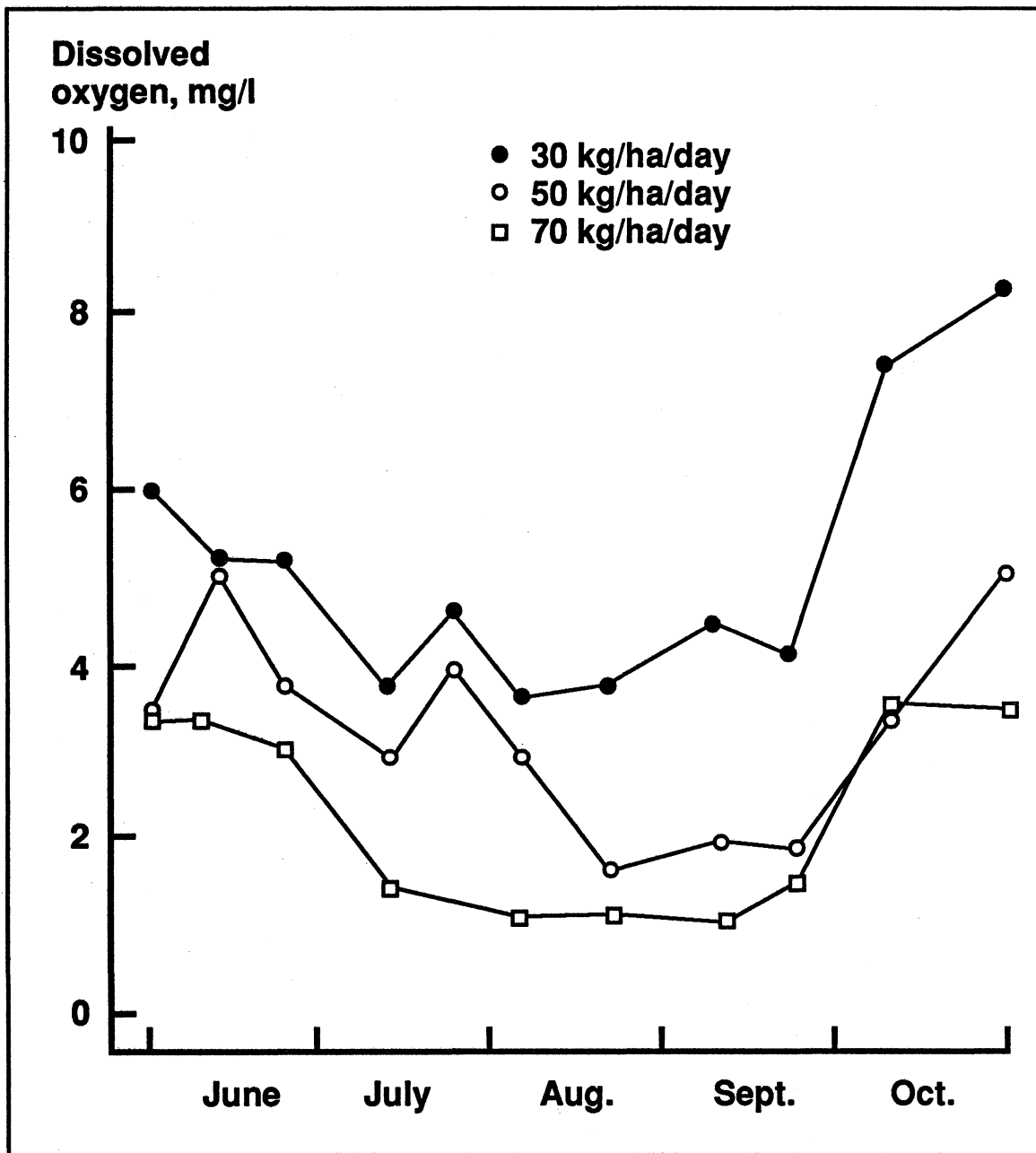

FIG. 14. Effect of feeding at three rates on dissolved oxygen concentrations at dawn in ponds.

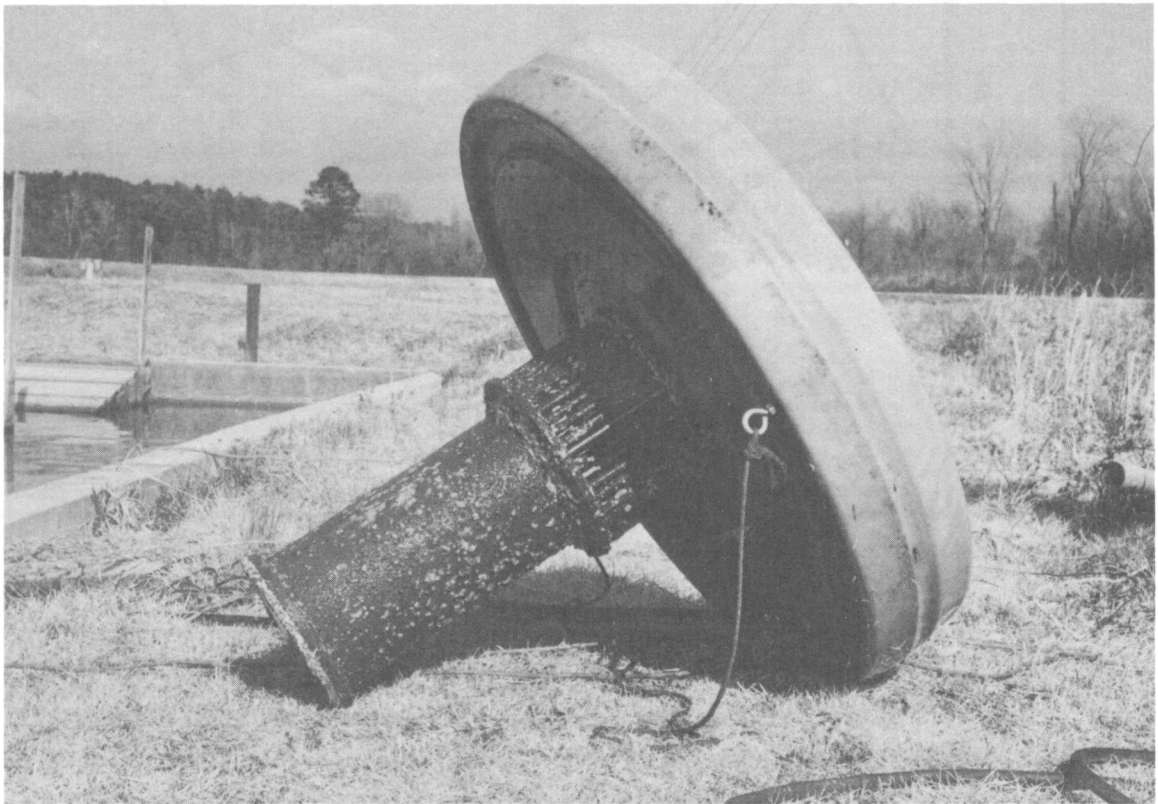
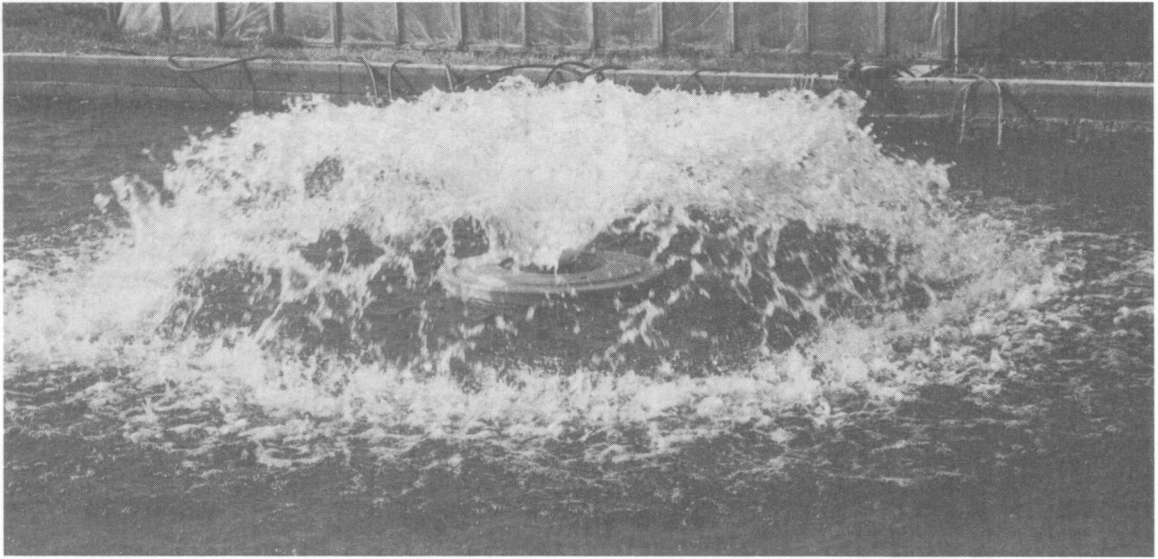

FIG. 15. A vertical pump aerator.



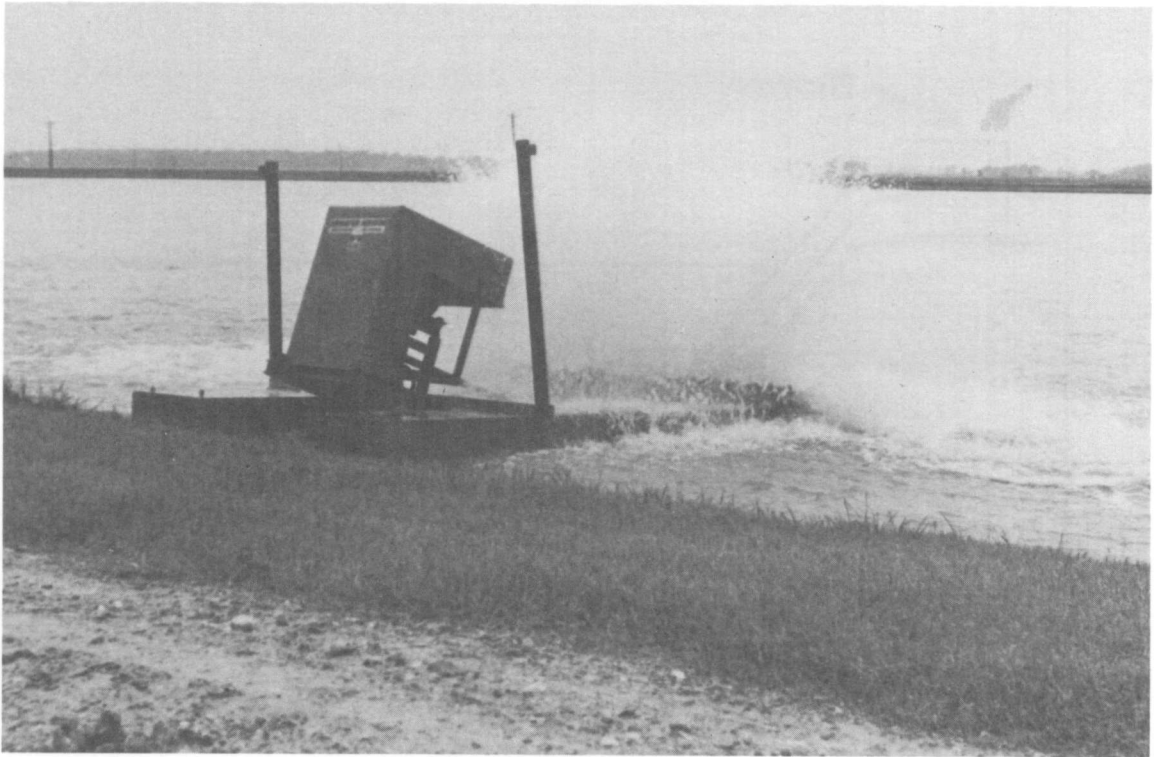

FIG. 16. A pump sprayer aerator.

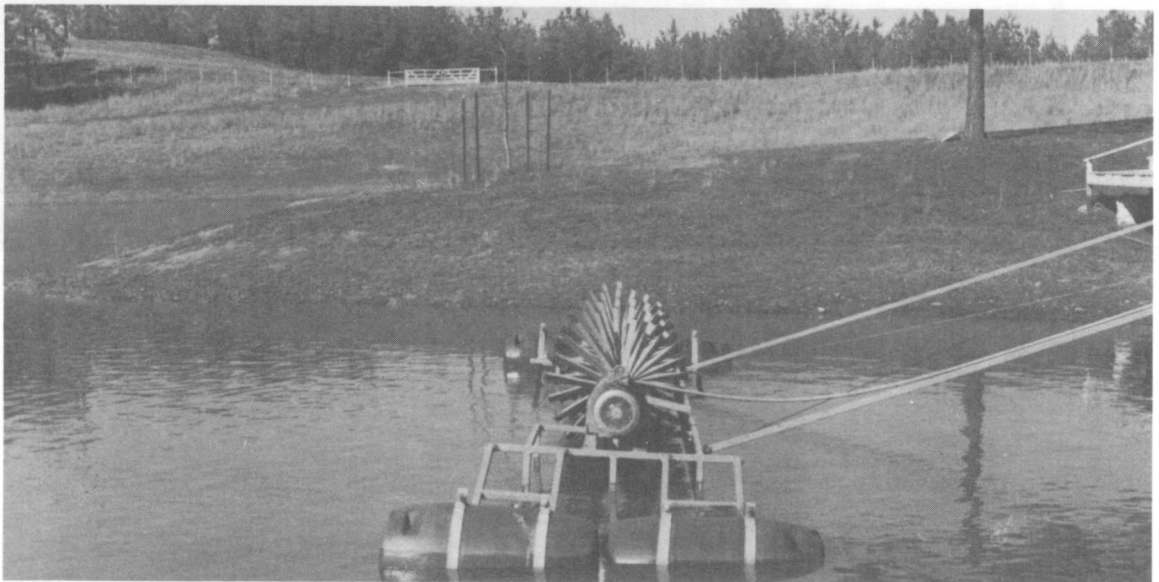

FIG. 17. A paddle wheel aerator.

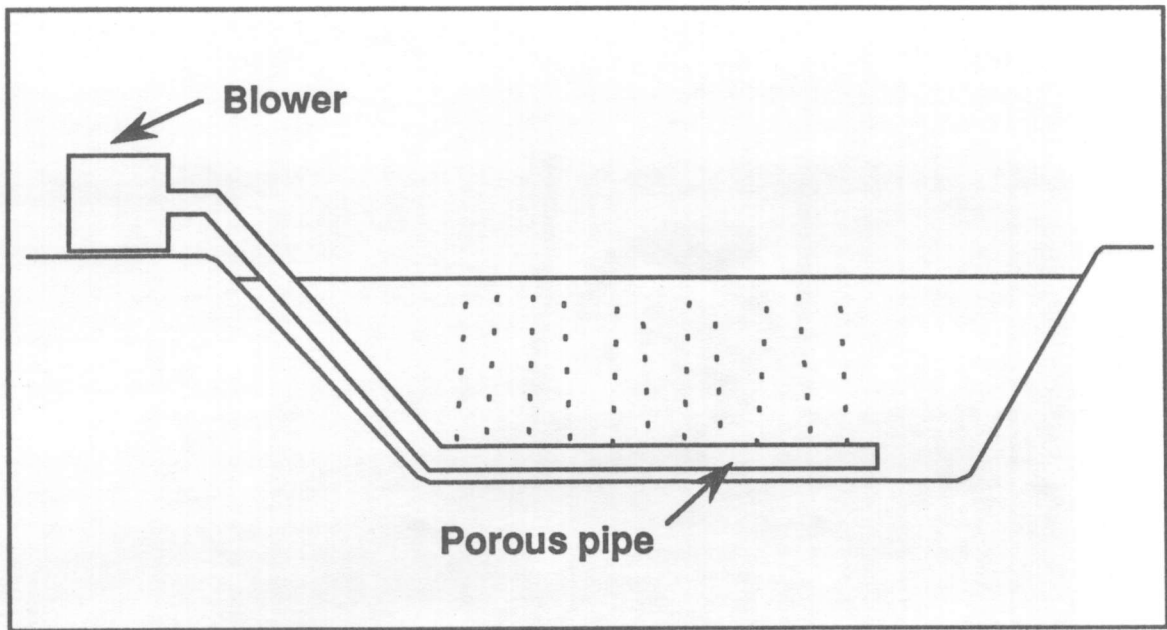

FIG. 18. A diffused-air aeration system.

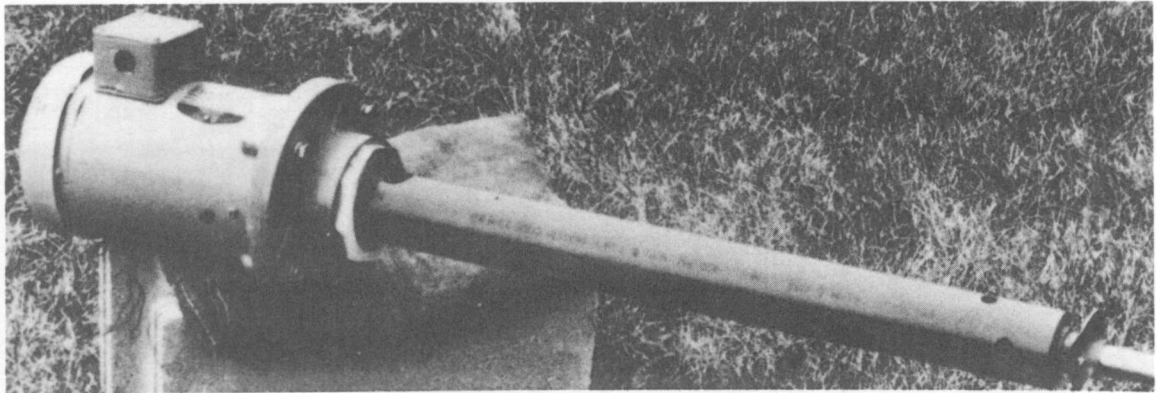

FIG. 19. A propeller-aspirator pump aerator.

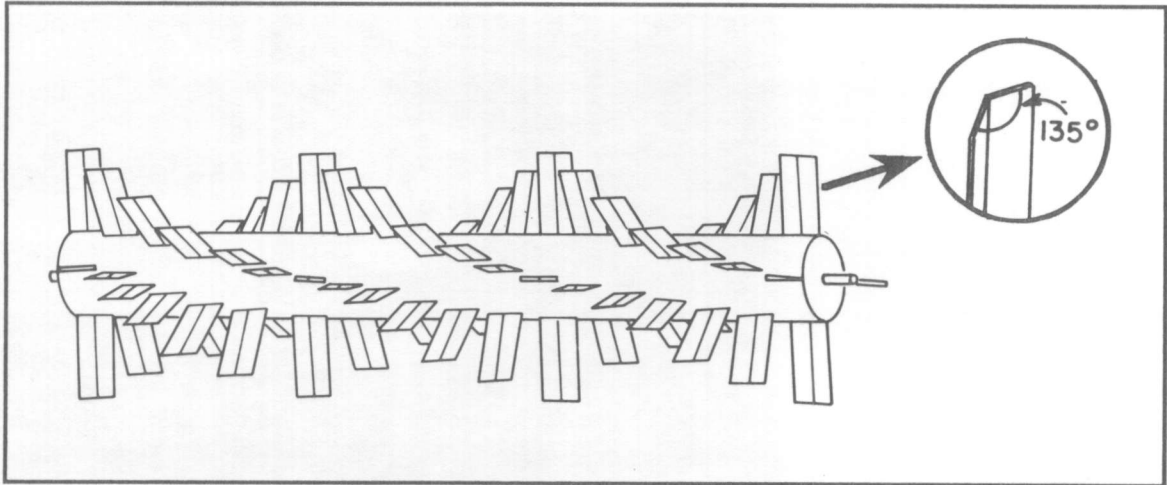

FIG. 20. Design for a highly efficient paddle wheel.

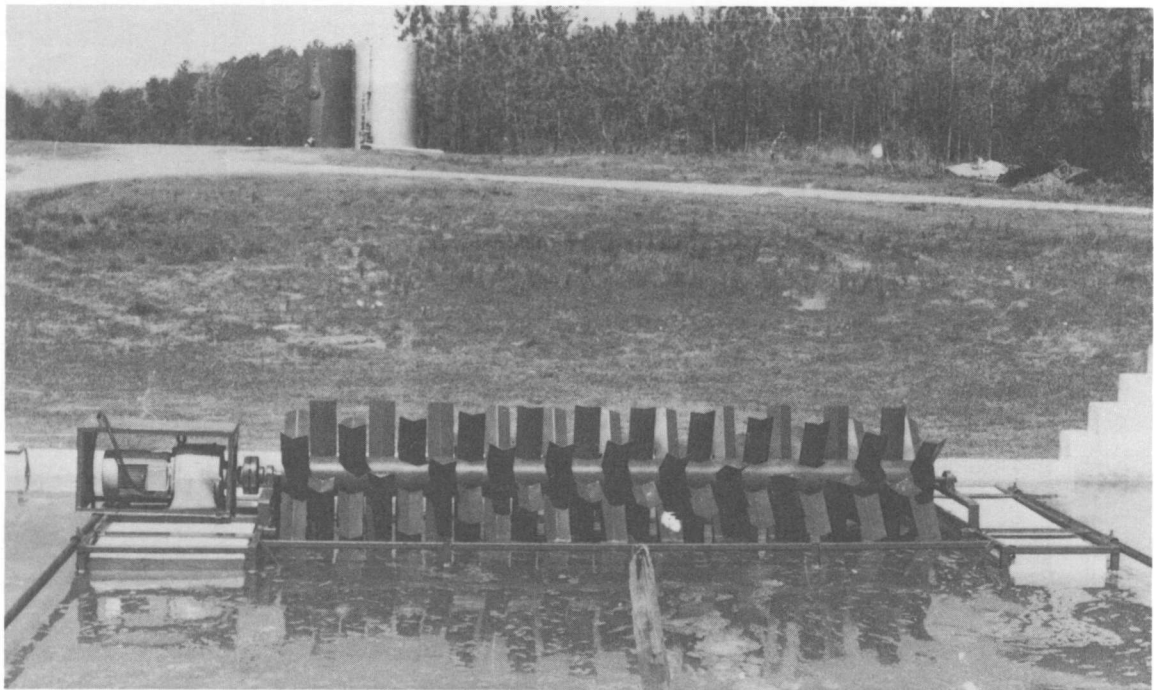

FIG. 21. A 7.5-kw, floating, electric, paddle wheel aerator.

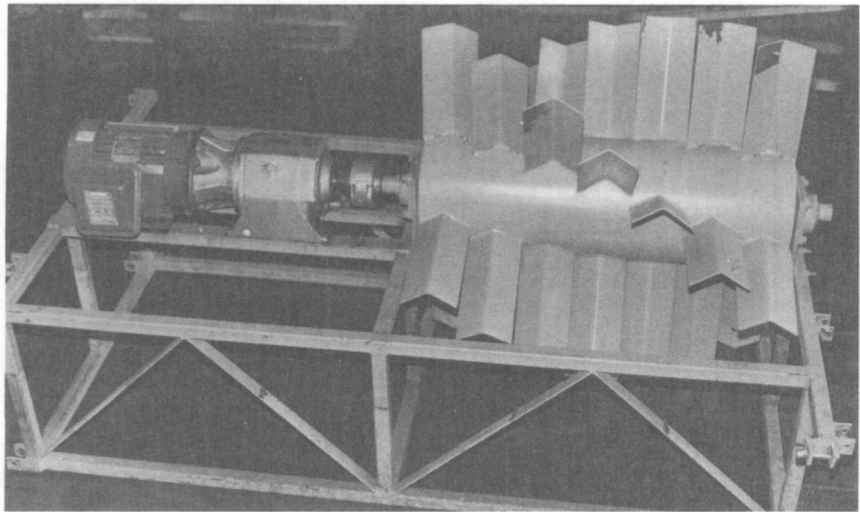

FIG. 22. A 2.25-kw, floating, electric, paddle wheel aerator without floats attached.

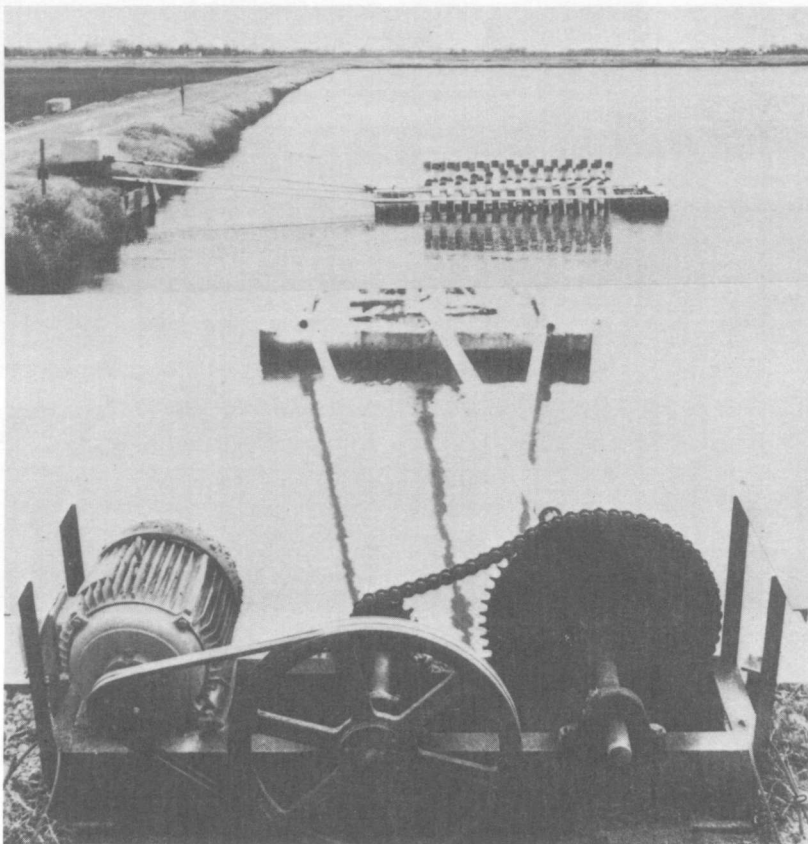

FIG. 23. A floating, paddle wheel aerator with gear reducer and motor on the pond bank.

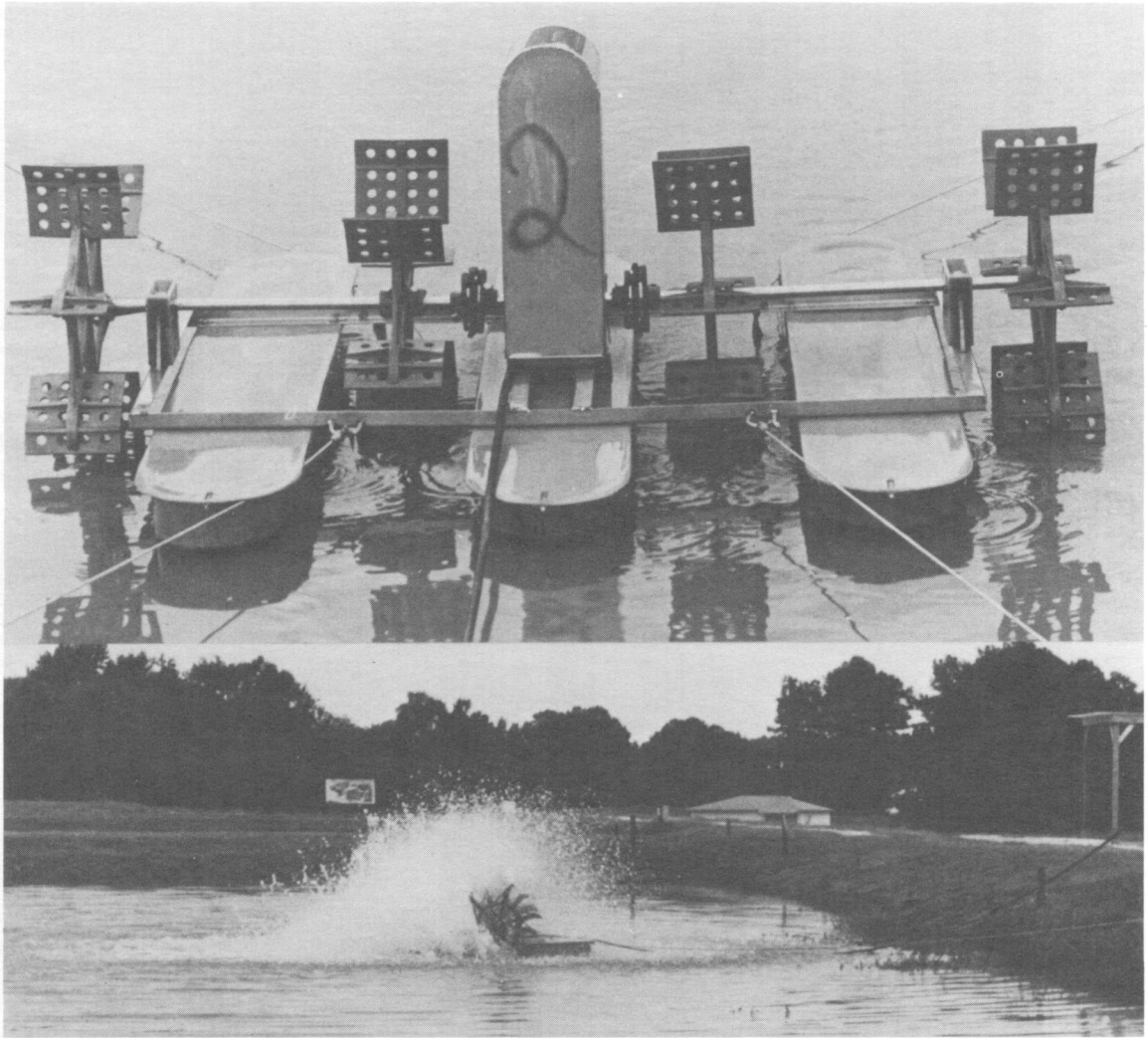

FIG. 24. A "Taiwanese" paddle wheel aerator.

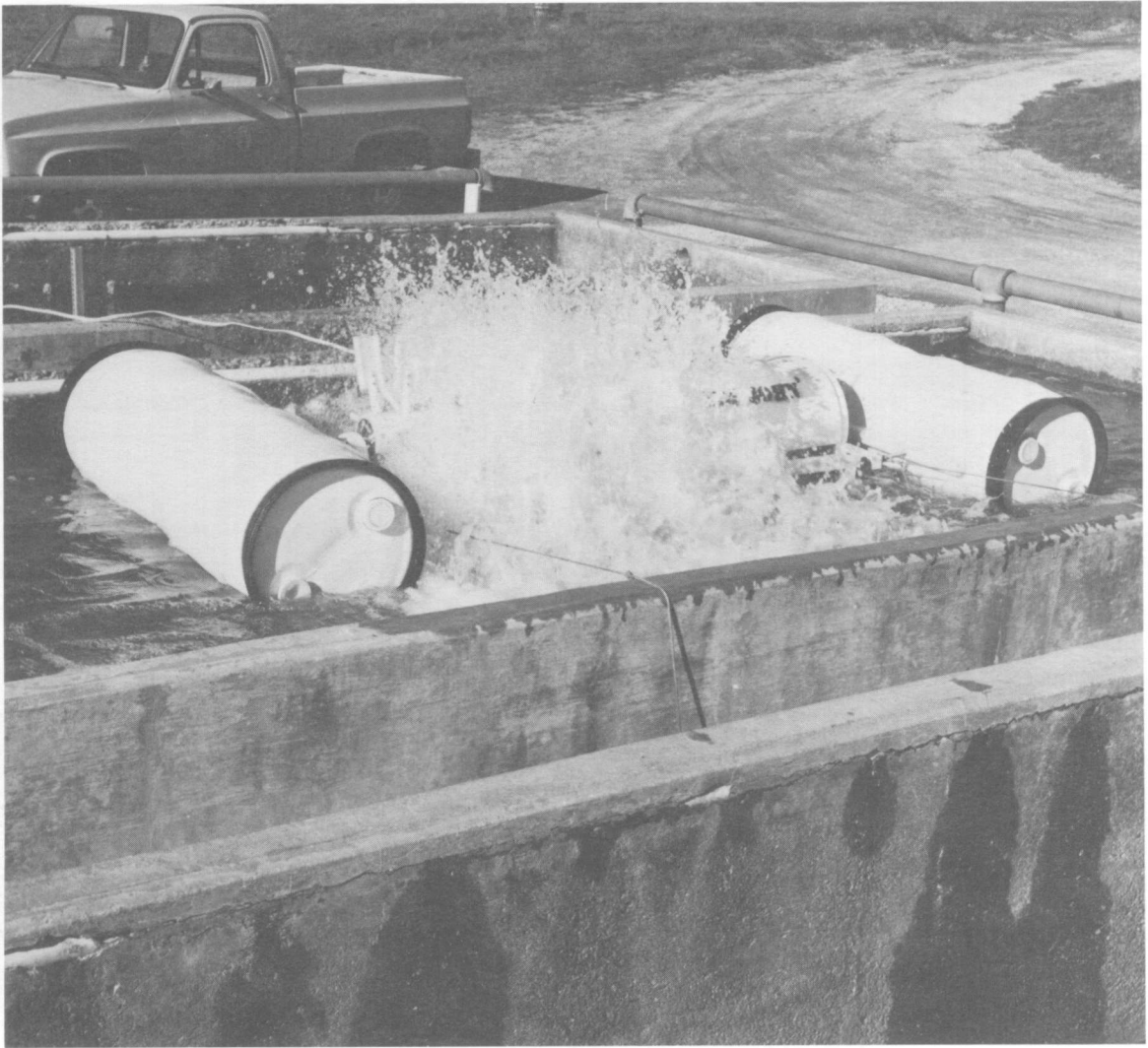

FIG. 25. A paddle wheel aerator constructed of polyurethane.

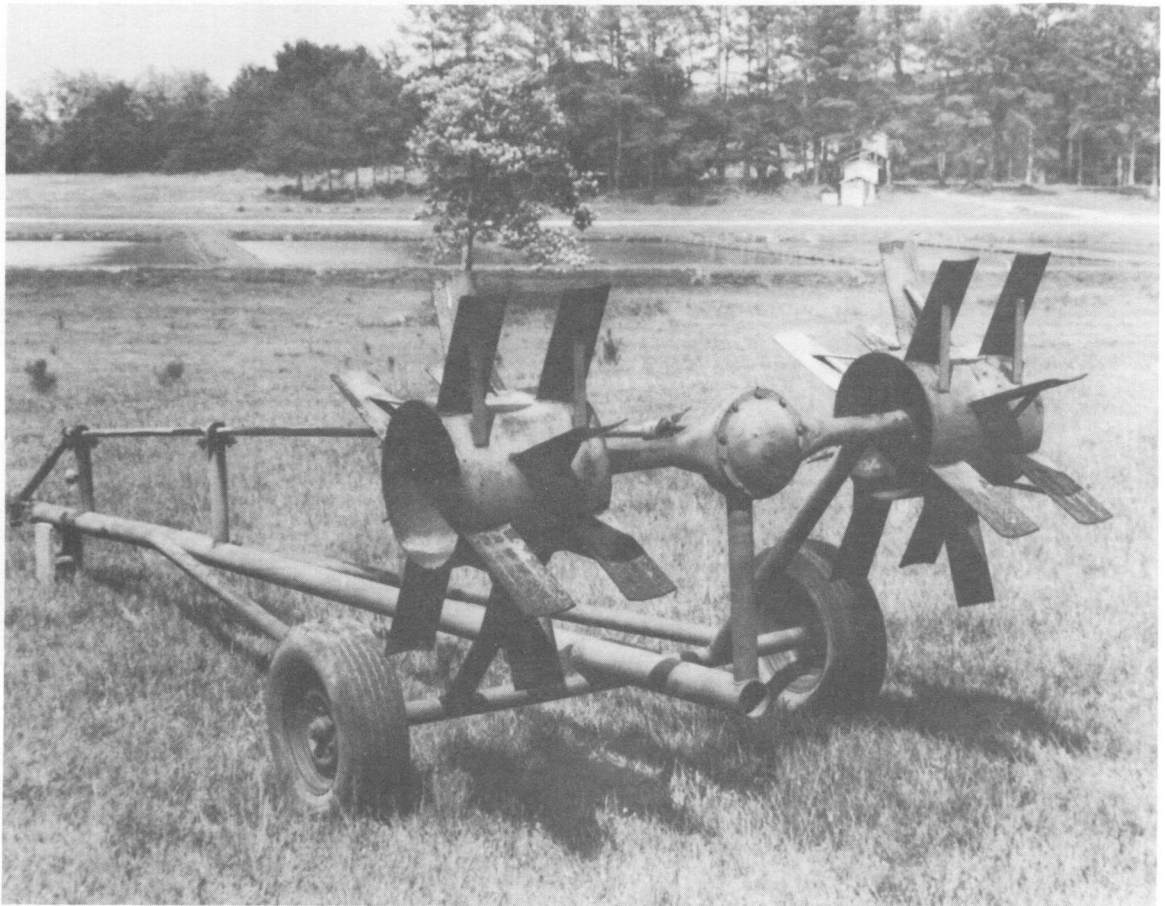

FIG. 26. A paddle wheel aerator which is powered by the power-take-off (PTO) of a farm tractor.

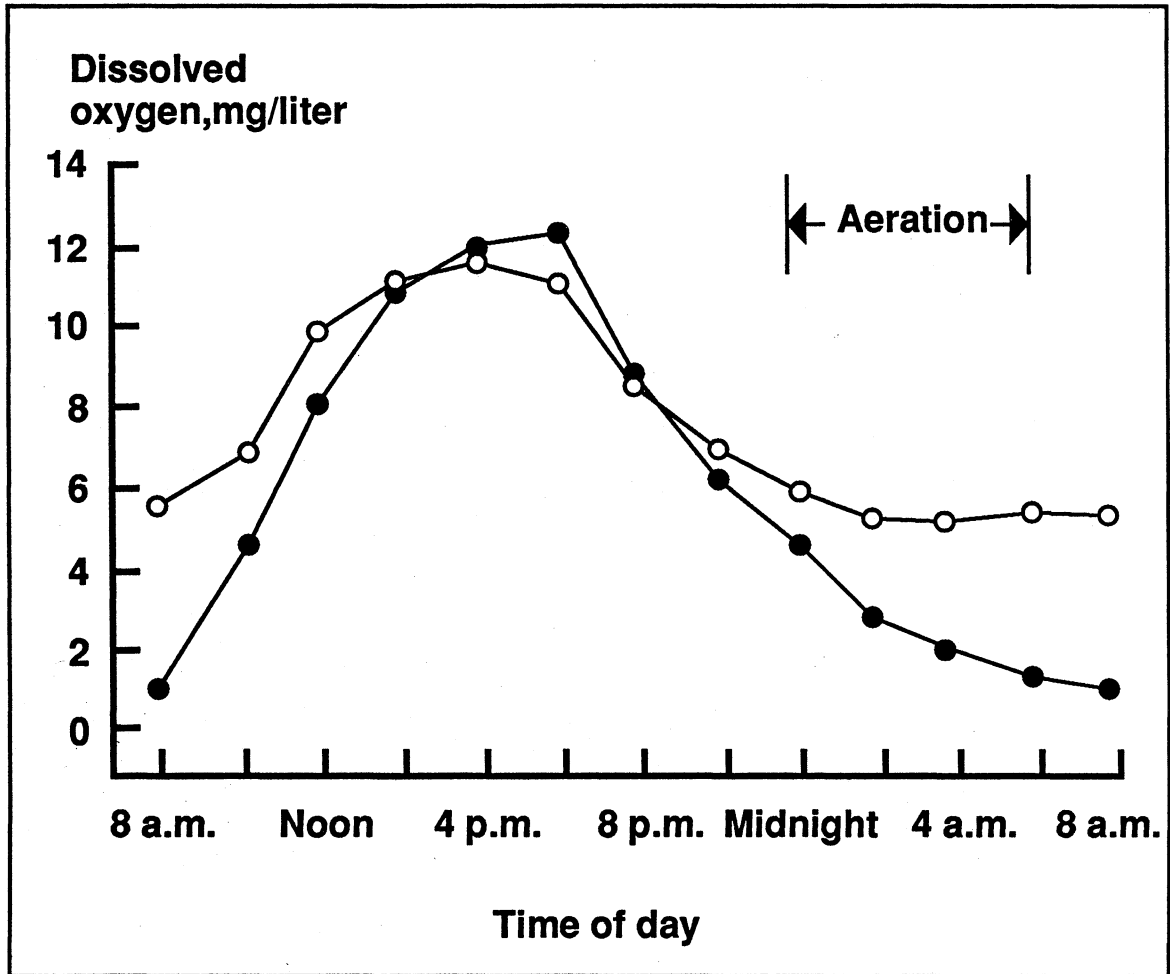

FIG. 27. Effect of nighttime aeration on dissolved oxygen concentrations in a pond.



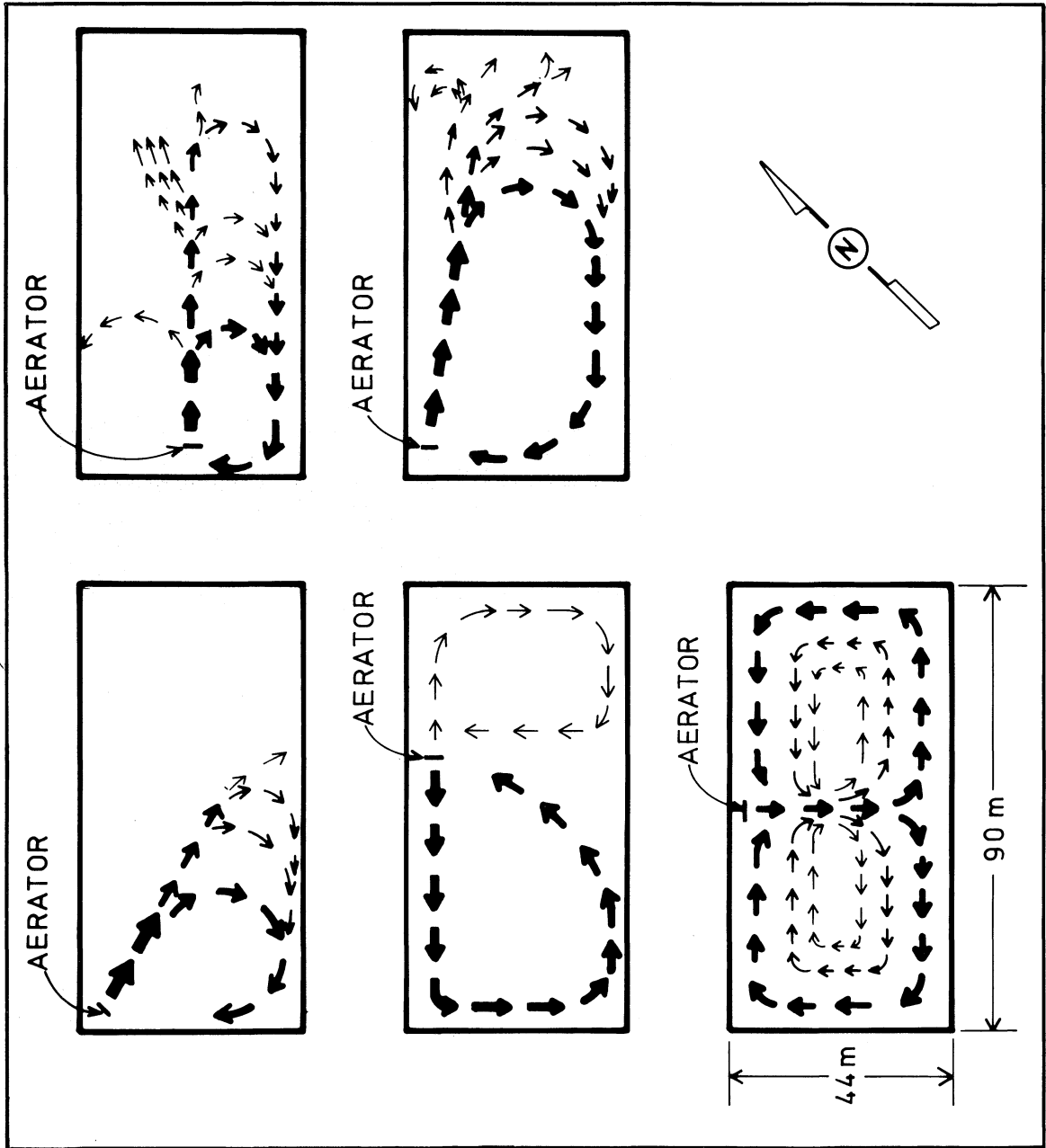

FIG. 28. Effect of paddle wheel aerator placement on water circulation patterns in ponds.

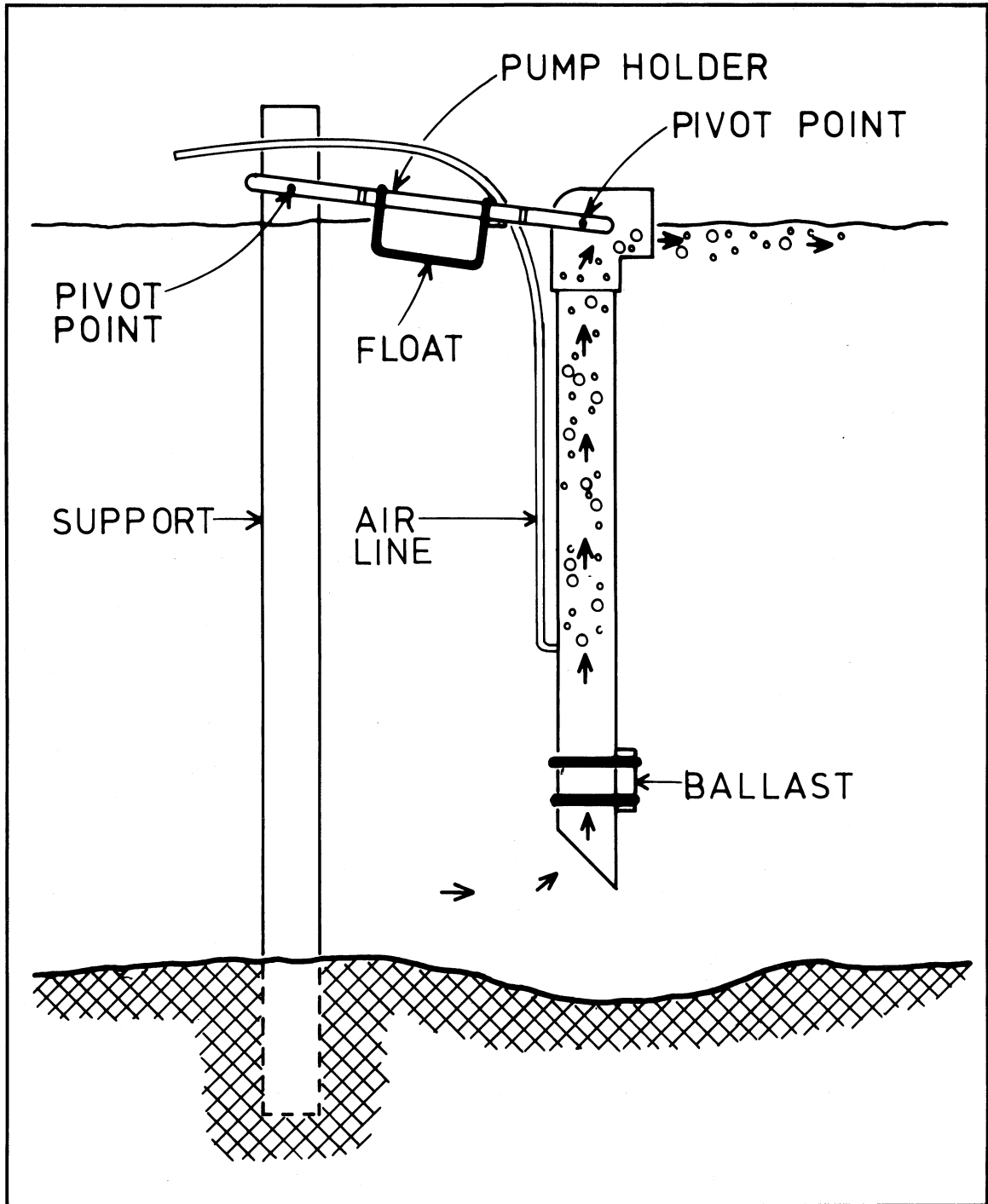

FIG. 29. An air-lift pump.

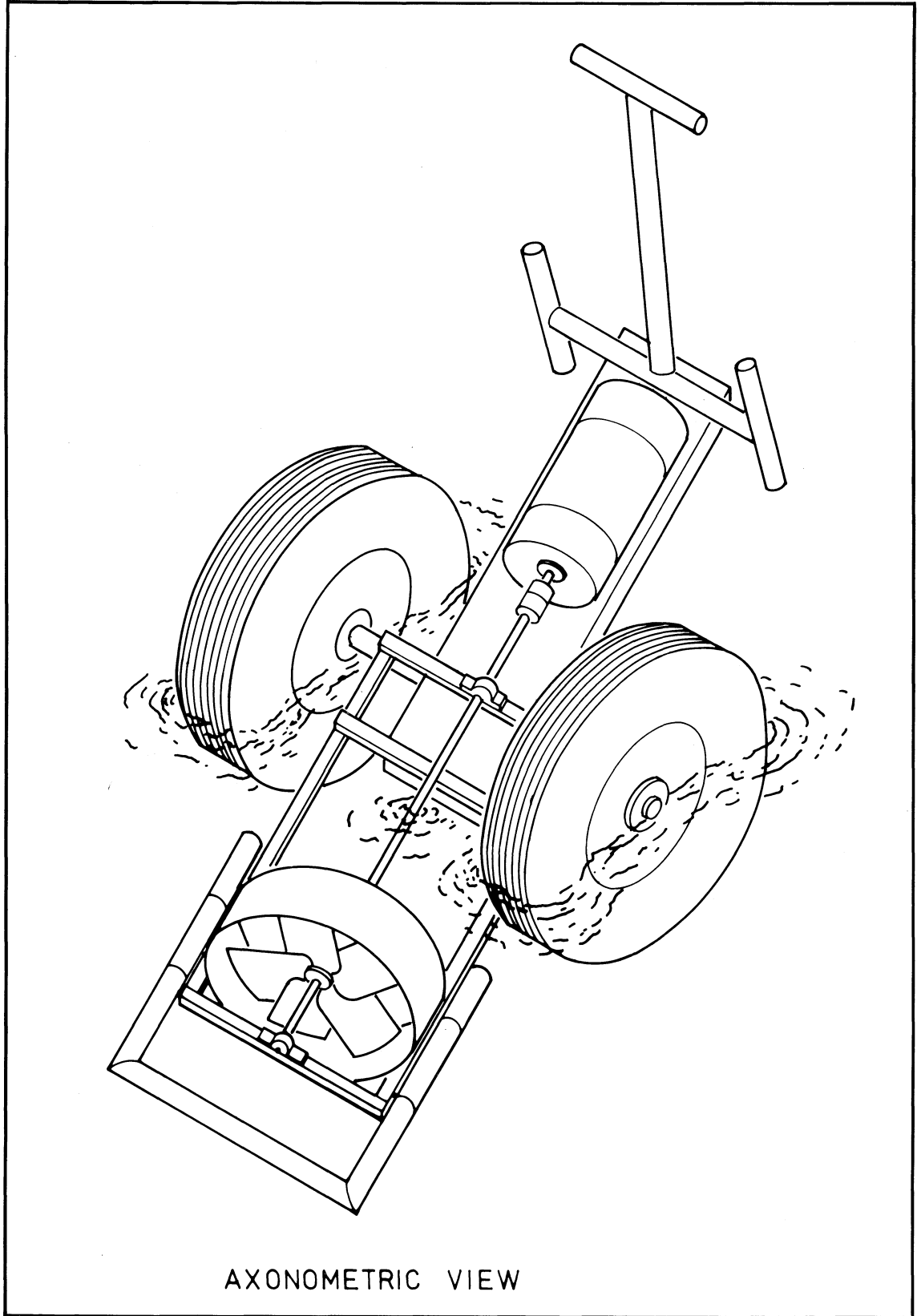

FIG. 30. A water circulator.

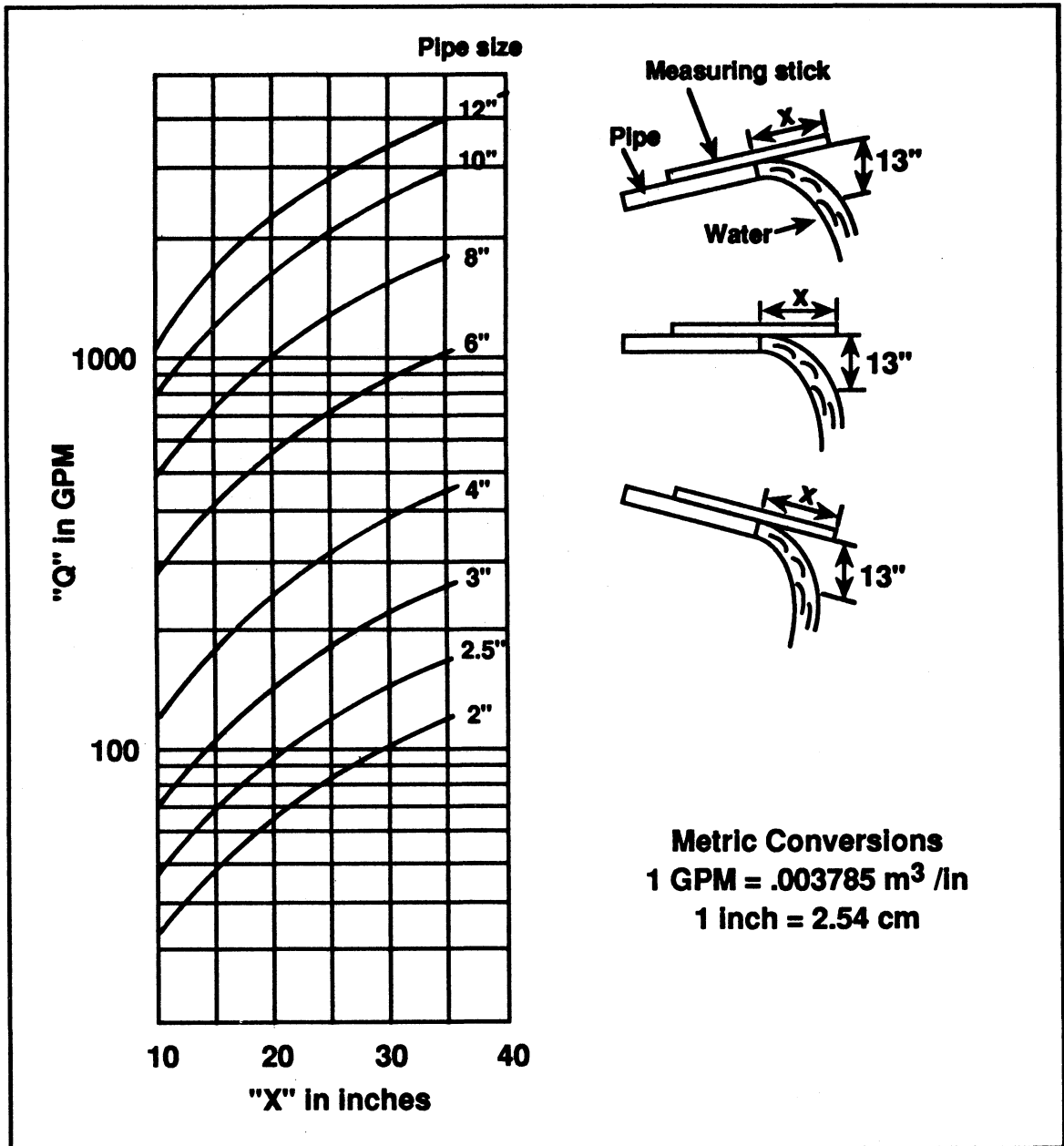

FIG. 31. A nomograph for estimating pipe discharge.

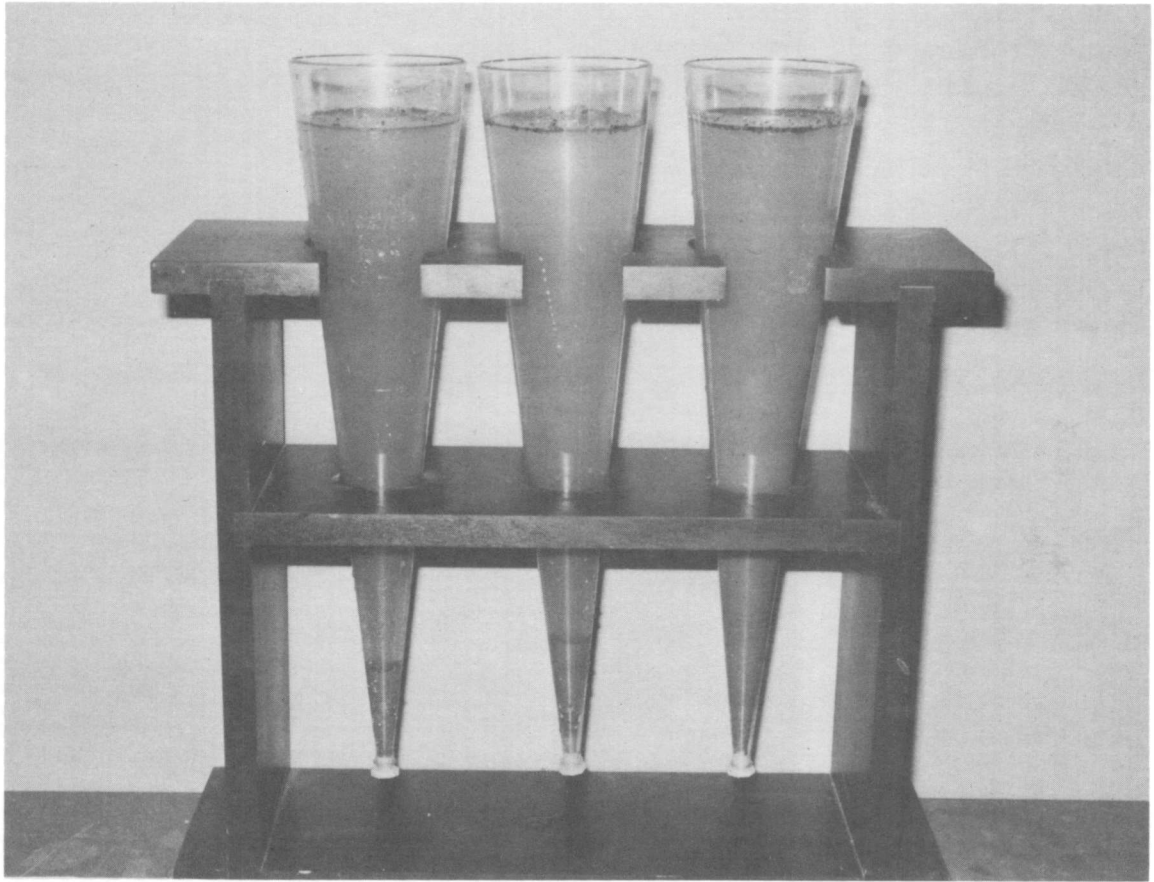

FIG. 32. An Imhoff cone.



## BIBLIOGRAPHY

- (1) AHMAD, T. AND C. E. BOYD. 1988. Design and Performance of Paddle Wheel Aerators. *Aquacultural Eng.*, 7: 39-62.
- (2) ALEXANDER, M. 1961. Introduction to Soil Microbiology. John Wiley and Sons, New York, 472 pp.
- (3) ALMAZAN, G. AND C. E. BOYD. 1978. An Evaluation of Secchi Disk Visibility for Estimating Plankton Density in Fish Ponds. *Hydrobiol.*, 65: 601-608.
- (4) ALMAZAN, G. AND C. E. BOYD. 1978. Effects of Nitrogen Levels on Rates of Oxygen Consumption During Decay of Aquatic Plants. *Aquatic Bot.*, 5: 119-126.
- (5) ANDREWS, J. W., T. MURAL, AND G. GIBBONS. 1973. The Influence of Dissolved Oxygen on the Growth of Channel Catfish. *Trans. Amer. Fish. Soc.*, 102: 835-838.
- (6) ASSOCIATION SOUTHEAST ASIAN NATIONS. 1978. Manual on Pond Culture of Penaeid Shrimp. National Coordinating Agency of the Philippines Ministry of Foreign Affairs, Manila, The Philippines.
- (7) BARICA, J. 1975. Summerkill Risk in Prairie Ponds and Possibilities of its Prediction. *J. Fish Res. Bd. Canada*, 32: 1283-1288.
- (8) BOYD, C. E. 1973. Summer Algal Communities and Primary Productivity in Fish Ponds. *Hydrobiol.*, 41: 357-390.
- (9) BOYD, C. E. 1973. The Chemical Oxygen Demand of Waters and Biological Materials from Ponds. *Trans. Amer. Fish. Soc.*, 102: 606-611.
- (10) BOYD, C. E. 1979. Aluminum Sulfate (Alum) for Precipitating Clay Turbidity from Fish Ponds. *Trans. Amer. Fish. Soc.*, 108: 307-313.
- (11) BOYD, C. E. 1981. Fertilization of Warmwater Fish Ponds. *J. Soil Water Cons.*, 36: 142-145.
- (12) BOYD, C. E. 1981. Solubility of Granular Inorganic Fertilizers for Fish Ponds. *Trans. Amer. Fish. Soc.*, 110: 451-454.
- (13) BOYD, C. E. 1982. Water Quality Management for Pond Fish Culture. Elsevier Sci. Publ. Co., Amsterdam, 319 pp.
- (14) BOYD, C. E. 1982. Hydrology of Small Experimental Fish Ponds at Auburn, Alabama. *Trans. Amer. Fish. Soc.*, 111: 638-644.
- (15) BOYD, C. E. 1985. Pond Evaporation. *Trans. Amer. Fish. Soc.*, 114: 299-303.

- (16) BOYD, C. E. 1985. Chemical Budgets for Channel Catfish Ponds. Trans. Amer. Fish. Soc., 114: 291-298.
- (17) BOYD, C. E. 1987. Evaluation of Water Quality and Water Quality Management Techniques for Brackishwater Aquaculture in Ponds in Thailand. Report for the Asian Development Bank, Manila, The Philippines, 29 pp.
- (18) BOYD, C. E. AND T. AHMAD. 1987. Evaluation of Aerators for Channel Catfish Farming. Alabama Agr. Exp. Sta., Bull. 584, Auburn University, 52 pp.
- (19) BOYD, C. E. AND H. V. DANIELS. 1987. Performance of Surface Aerators in Saline Pond Waters. Prog. Fish-Cult., 49: 306-308.
- (20) BOYD, C. E. AND H. V. DANIELS. 1988. Evaluation of Hatch Fish Farmer's Water Quality Test Kits for Saline Water. J. World Aquaculture Soc., 19: In press.
- (21) BOYD, C. E. AND F. LICHTKIPPLER. 1979. Water Quality in Fish Culture. Ala. Agr. Exp. Sta., Res. and Dev. Series No. 22, Auburn University, 30 pp.
- (22) BOYD, C. E., T. AHMAD, AND Z. LAI-FA. 1987. Evaluation of Plastic Pipe, Paddle Wheel Aerators. Aquacultural Eng., 7: 63-72.
- (23) BOYD, C. E., E. E. PRATHER, AND R. W. PARKS. 1975. Sudden Mortality of a Massive Phytoplankton Bloom. Weed Sci., 23: 61-76.
- (24) BOYD, C. E., R. P. ROMAIRE, AND E. JOHNSTON. 1978. Predicting Early Morning Dissolved Oxygen Depletion in Channel Catfish Ponds. Trans. Amer. Fish. Soc., 107: 484-492.
- (25) BOYD, C. E., J. A. STEEBY, AND E. W. McCOY. 1979. Frequency of Low Dissolved Oxygen Concentrations in Ponds for Commercial Culture of Channel Catfish. Proc. Annual Conf. Southeast. Assoc. Fish and Wildlife Agencies, 33: 591-599.
- (26) BOYD, C. E., W. D. HOLLERMAN, J. A. PLUMB, AND M. SAEED. 1984. Effect of Treatment With a Commercial Bacterial Suspension on Water Quality in Channel Catfish Ponds. Prog. Fish-Cult., 46: 36-40.
- (27) BRINKMAN R. AND V. P. SINGH. 1982. Rapid Reclamation of Brackish Water Fishponds in Acid Sulphate Soils, p. 318-330. In: H. Dost and N. van Breemen (eds.), Proc. of the Bangkok Symposium on Acid Sulfate Soils, Internat. Inst. Land Reclamation and Improvement, Publ. 18, Wageningen, The Netherlands.
- (28) BUSCH, C. D. 1980. Circulation for Pond Aeration and Energy Conservation, Proc. World Mariculture Soc., 11: 93-101.



- (29) BUSCH, C. D., AND C. A. FLOOD, Jr. 1980. Water Movement for Water Quality in Catfish Production. Trans. Amer. Soc. Agric. Eng., 23: 1040-1042,
- (30) BUSCH, C. D., C. A. FLOOD, Jr., AND R. ALLISON. 1972. Multiple Paddlewheels' Influence on Fish Pond Temperature and Aeration. Trans. Amer. Soc. Agric. Eng., 21: 1222-1224.
- (31) CARPENTER, K. E., A. W. FAST, V. L. CORRE, J. W. WOESSNER, AND R. L. JANE0. 1988. The Effects of Water Depth and Circulation on the Water Quality and Production of Penaeus monodon in Earthen Ponds. CRSP Research Dept. 88-6, Oregon State University, Corvallis, 4 pp.
- (32) COLE, B. A. AND C. E. BOYD. 1986. Feeding Rate, Water Quality, and Channel Catfish Production in Ponds. Prog. Fish-Cult., 48: 25-29.
- (33) COLT, J. 1984. Computation of Dissolved Gas Concentrations in Water as Functions of Temperature, Salinity, and Pressure. Amer. Fish. Soc., Spec. Publ. No. 14, Bethesda, Maryland, 154 pp.
- (34) DENT, D. 1986. Acid Sulfate Soils: A Baseline for Research and Development. Internat. Inst. Land Reclamation and Improvement, Publ. 39, Wageningen, The Netherlands, 204 pp.
- (35) DOBBINS, D. A. AND C. E. BOYD. 1976. Phosphorus and Potassium Fertilization of Sunfish Ponds. Trans. Amer. Fish. Soc., 105: 536-540.
- (36) EMERSON, K., C. RUSSO, R. LUND, AND R. V. THRUSTON. 1975. Aqueous Ammonia Equilibrium Calculations: Effects of pH and Temperature, J. Fish. Res. Bd. Canada, 32, 2379.
- (37) FLEMING, J. F. AND L. T. ALEXANDER. 1961. Sulfur Acidity in South Carolina Tidal Marsh Soils. Soil Sci. Soc. Amer. Proc., 25: 94-95.
- (38) FAST, A. W., D. K. BARCLAY, AND G. AKIYAMA. 1983. Artificial Circulation of Hawaiian Prawn Ponds, University of Hawaii, UNIHI-SEAGRANT-CR-84-01, Honolulu, 82 pp.
- (39) FAST, A. W. 1986. Pond Production Systems: Water Quality Management Practices, p. 141-168. In: J. E. Lannan, R. O. Smitherman, and G. Tchobanoglous (eds.), Principles and Practices of Pond Aquaculture, Oregon State University Press, Corvallis.
- (40) HEPHER, B. 1962. Primary Production in Fishponds and Its Application to Fertilization Experiments. Limnol. Oceanogr., 7: 131-135.
- (41) HOLLERMAN, W. D. AND C. E. BOYD. 1980. Nightly Aeration to Increase Production of Channel Catfish. Trans. Amer. Fish. Soc., 109: 446-452.

- (42) LAI-FA, Z. AND C. E. BOYD. 1988. Nightly Aeration to Increase the Efficiency of Channel Catfish Production. Prog. Fish-Cult., 50: In press.
- (43) LAWRENCE, J. M. 1954. A New Method of Applying Inorganic Fertilizer to Farm Fish Ponds. Prog. Fish-Cult., 16: 176-178.
- (44) LEOPOLD AND STEVENS, INC. 1978. Stevens Water Resources Data Book. Leopold and Stevens, Inc., Beaverton, Oregon, 154 pp.
- (45) LOYACANO, H. A. 1974. Effects of Aeration in Earthen Ponds on Water Quality and Production of White Catfish. Aquaculture, 3: 261-171.
- (46) METZGER, R. J. AND C. E. BOYD. 1980. Liquid Ammonium Polyphosphate as a Fish Pond Fertilizer. Trans. Amer. Fish. Soc., 109: 563-570.
- (47) MUSIG, Y. AND W. RUTTANAGOSRIGIT. 1982. Effects of Salinity on Survival Rate of Penaeus monodon Larvae. Brackishwater Fisheries Division, Thai. Dept. of Fisheries, Rept. No. 5, Bangkok, Thailand, 10 pp.
- (48) PARKER, N. C. 1979. Channel Catfish Production in Continuously Aerated Ponds. Research Workshop, Catfish Farmers of America, Jackson, Mississippi.
- (49) PARKER, N. C. 1983. Air-Lift Pumps and Other Aeration Techniques, p. 24-27. In: Water Quality in Channel Catfish Ponds, Tucker, C. S., (ed.), Southern Coop. Series Bull. 290, Mississippi Agr. and Forestry Exp. Sta., Mississippi State, Mississippi.
- (50) PILLAI, V. K. AND C. E. BOYD. 1985. A Simple Method for Calculating Liming Rates for Fish Ponds. Aquaculture, 46: 157-162.
- (51) PLEMMONS, B. P AND JAMES W. AVAULT, JR. 1980. Six Tons of Catfish Per Acre With Constant Aeration. Louisiana Agriculture, Louisiana State Univ. Agr. Ex. Sta., 23: 6-9.
- (52) PLUMB, J. A., J. M. GRIZZLE, AND J. DEFIGUEIREDO. 1976. Necrosis and Bacterial Infection in Channel Catfish (Ictalurus punctatus) Following Hypoxia. J. Wildlife Diseases, 12: 247-253.
- (53) RICHARD, D. T. 1973. Sedimentary Iron Formation, p. 28-65. In: H. Dost (ed.), Proc. Int. Symp. on Acid-Sulfate Soils, Vol. I. Inst. Land Reclamation and Improvement, Wageningen, The Netherlands.
- (54) ROMAIRE, R. P. AND C. E. BOYD. 1979. Effects of Solar Radiation on the Dynamics of Dissolved Oxygen in Channel Catfish Ponds. Trans. Amer. Fish. Soc., 108: 473-478.

- (55) SANARES, R. C., S. A. KATASE, A. W. FAST, AND K. E. CARPENTER. 1988. Water Quality Dynamics in Brackishwater Shrimp Ponds With Artificial Aeration and Circulation. CRSP Research Rept. 88-7, Oregon State University, Corvallis.
- (56) SHELTON, J. L., Jr. AND C. E. BOYD. 1983. Correction Factors for Calculating Oxygen-Transfer Rates of Pond Aerators. Trans. Amer. Fish. Soc., 112: 120-122.
- (57) SMITH, L. L., Jr., D. M. OSEID, G. L. KIMBALL, AND S. M. EL-KANDELGY. 1976. Toxicity of Hydrogen Sulfide to Various Life History Stages of Bluegill (Lepomis macrochirus). Trans. Amer. Fish. Soc., 105: 442-449.
- (58) TRUSSELL, R. P. 1971. The Percent Un-ionized Ammonia in Aqueous Ammonia Solutions at Different pH Levels and Temperature. J. Fish. Res. Bd. Canada, 29, 1505-1507.
- (59) TUCKER, C. S. AND C. E. BOYD. 1985. Water Quality, p. 135-228. In: C. S. Tucker (ed.), Channel Catfish Culture, Elsevier Sci. Publ. Co., Amsterdam.
- (60) WALTERS, G. R. AND J. A. PLUMB. 1980. Environmental Stress and Bacterial Infection in Channel Catfish, Ictalurus punctatus Rafinesque. J. Fish. Biol., 17: 177-185.

# Alabama's Agricultural Experiment Station System

## Auburn University

★ Main Agricultural Experiment Station, Auburn

☆ E.V. Smith Research Center, Shorter

1. Tennessee Valley Substation, Belle Mina
2. Sand Mountain Substation, Crossville
3. North Alabama Horticulture Substation, Cullman
4. Upper Coastal Plain Substation, Winfield
5. Forestry Unit, Fayette County
6. Chilton Area Horticulture Substation, Clanton
7. Forestry Unit, Coosa County
8. Piedmont Substation, Camp Hill
9. Plant Breeding Unit, Tallassee
10. Forestry Unit, Autauga County
11. Prattville Experiment Field, Prattville
12. Black Belt Substation, Marion Junction
13. The Turnipseed-Ikenberry Place, Union Springs
14. Lower Coastal Plain Substation, Camden
15. Forestry Unit, Barbour County
16. Monroeville Experiment Field, Monroeville
17. Wiregrass Substation, Headland
18. Brewton Experiment Field, Brewton
19. Solon Dixon Forestry Education Center, Covington and Escambia counties
20. Ornamental Horticulture Substation, Spring Hill
21. Gulf Coast Substation, Fairhope

